

## Working Instruction english

Revision	A
Datum	16.05.2007
Ersteller	NH

This operating instruction is not subject to the updating

## Parking Station

**1-95813-9-00034-AAAA-Z03**

Vor Beginn aller Arbeiten  
Betriebsanleitung lesen!

*Read operating instruction  
before beginning of all works!*

Betriebsanleitung immer  
**AUFBEWAHREN!**  
griffbereit am Gerät

*Always KEEP operating  
instruction! In a ready hand  
way at the device*

**Achtung:** Vor Inbetriebnahme  
Gerät auf mängelfreien Zustand  
und technisch einwandfreie  
Funktion kontrollieren.

*Caution: Before starting-up  
check device on faultless  
condition and technically  
perfect function.*

Das Original ist die  
deutsche Fassung

*The German version  
is the original*

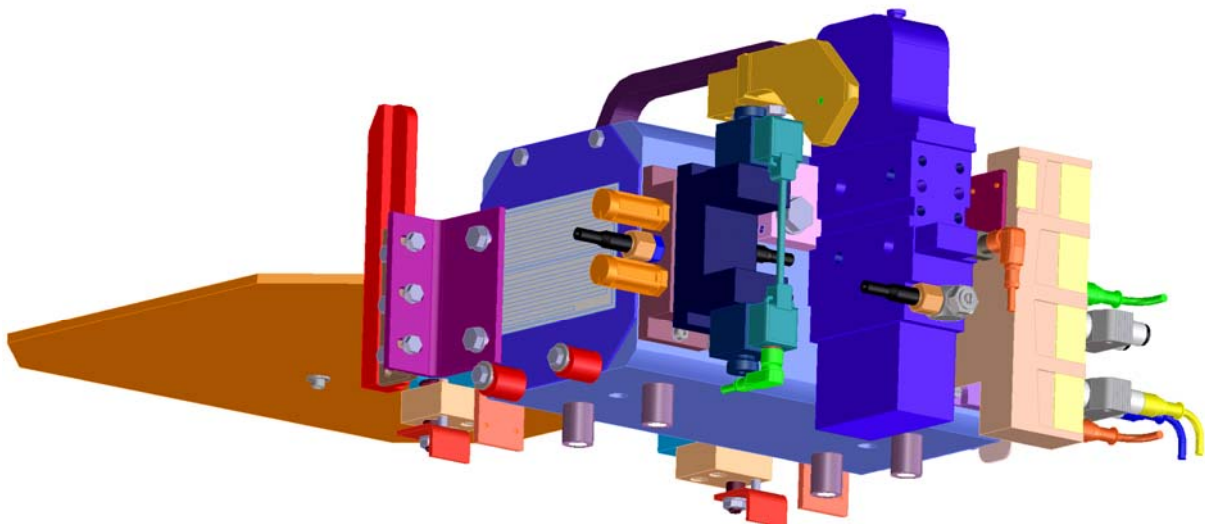

This parking station is a quality product, in which special attention has been paid to high functionality, ease of operation, safety and reliability. As an item of technical equipment this parking station is intended for use in the commercial, industrial area and for operators, who have been trained by specialists in the handling of technical systems / tools.

**Customer care:**

As part of our individual customer care we will be happy to assist you in questions relating to use and operation and on any problems encountered.

**Service and maintenance:**

In order to maintain the high technical performance capability and reliability of your parking station over many years, we recommend regular inspection and maintenance.

We can thereby offer you optimum support by our Customer Service department and the conclusion of a service and maintenance contract.  
Please ask for a quotation.

Carl Kurt Walther GmbH & Co. KG  
PO Box 42 04 44  
42781 Haan  
Westfalenstraße 2

Tel.: +49 (0) 2129 567-0  
Fax: +49 (0) 2129 567 450

E-Mail: [info@walther-precision.de](mailto:info@walther-precision.de)  
Internet: [www.walther-precision.de](http://www.walther-precision.de)

**Contact:**

**Application technology and service**

Holger R. Figge  
Telephone: (02129) 567-591  
Telefax: (02129) 567-590  
Handy: (0162) 2090100  
e-mail: [hfigge@walther-precision.de](mailto:hfigge@walther-precision.de)

Further addresses and telephone numbers of contacts can be found on the Internet on our homepage under [www.walther-precision.de](http://www.walther-precision.de) "Service / Customer service".

## List of Contents

### 1 List of Contents

<b>1</b>	<b>LIST OF CONTENTS .....</b>	<b>3</b>
<b>2</b>	<b>GENERAL.....</b>	<b>4</b>
<b>3</b>	<b>SAFETY INSTRUCTIONS.....</b>	<b>5</b>
<b>4</b>	<b>WARRANTY.....</b>	<b>6</b>
<b>5</b>	<b>GENERAL DESCRIPTION OF TOOL PARKING STATION.....</b>	<b>7</b>
<b>6</b>	<b>TECHNICAL DATA .....</b>	<b>7</b>
<b>7</b>	<b>DESCRIPTION OF EQUIPMENT .....</b>	<b>8</b>
7.1	STAND.....	8
7.2	LEVEL ADJUSTMENT.....	8
7.3	SUPPORT.....	8
7.4	PROTECTION COVER .....	8
7.5	INSTALLATION PACKAGE ELECTRO.....	8
7.6	INSTALLATION PACKAGE PNEUMATIC .....	8
<b>8</b>	<b>ASSEMBLY AND INSTALLATION.....</b>	<b>9</b>
8.1	GENERAL SAFETY INSTRUCTIONS .....	9
8.2	ERECTION.....	9
8.3	PNEUMATIC INSTALLATION .....	9
8.4	ELECTRICAL INSTALLATION .....	10
<b>9</b>	<b>COMMENTS TO APPLICATION PREPARATION .....</b>	<b>11</b>
<b>10</b>	<b>COMMISSIONING, WORKING AND MAINTENANCE .....</b>	<b>12</b>
10.1	GENERAL SAFETY INSTRUCTIONS .....	12
10.2	PREVENTIVE CHECKS.....	12
10.3	MAINTENANCE.....	12
<b>11</b>	<b>WORKS ON MALFUNCTIONS AND DAMAGES.....</b>	<b>13</b>
11.1	GENERAL SAFETY INSTRUCTIONS .....	13
11.2	MALFUNCTIONS AND ASSESSMENT OF DAMAGE .....	13
11.3	REPAIR .....	13
<b>12</b>	<b>DRAWINGS AND PARTS LISTS .....</b>	<b>14</b>
12.1	1-95813-9-00034-AAAA-Z03 PARKING STATION .....	15
12.2	1-95813-B-00003-AAAA-Z03 SUPPORT FOR WELDING GUNS.....	18
12.3	1-95813-B-00008-AAAA-Z03 HINGED COVER .....	23
12.4	1-95813-E-00008-AAAA-Z03 ELECTRICAL EQUIPMENT .....	27
12.5	1-95813-P-00007-AAAA-Z03 INSTALLATIONSPAKET PNEUMATIK .....	30
12.6	1-95813-B-00005-AAAA-Z03 TOOL IDENTIFICATION .....	33
12.7	1-95813-B-00006-AAAA-Z03 SECURITY MODULE (PARKING STATION).....	37
12.8	1-95813-B-00016-AAAA-Z03 INSCRIPTION .....	40
<b>13</b>	<b>INDEX .....</b>	<b>43</b>

## 2 General

This manual contains all regulations for operation, commissioning and maintenance of the parking station 95813.

All information and notes in this operating manual were collated while taking into consideration the valid regulations, the current engineering related status of development as well as our many years of experience and acquired knowledge.

Translations of this operating manual were also produced according to the best of knowledge. However, we cannot assume liability for any translation errors. The German version provided for this operating manual is considered the authoritative version.

The actual scope of delivery can deviate from the explanations and graphic representations described herein under certain circumstances, e.g. in the case of special designs, utilization of additional order options or because of state-of-the-art technical alterations.

If you have any questions, please contact the manufacturer.



This operating manual must be read carefully before starting work on or with the equipment, in particular before commissioning!

The manufacturer assumes no liability for damage or faults arising from non-compliance with the instructions in this operating manual.

The operating manual must be kept directly with the equipment and be accessible to all persons who work on or with the equipment.

It is not permitted for the operating manual to be passed to third parties and if applicable this will incur damage compensation. All other rights reserved.

Before commissioning the device must be checked for being not defective and its technically perfect function.

The German version is the original.

We reserve the right to make technical alterations to the product within the context of improving the usage properties and further development.

The operating manual remains our property.

Any reproduction, use by or communication to third parties incurs a penalty and will be pursued by court action (copyright law against unfair competition, BGB [German Civil Code]). All rights reserved in the case of a patent award (Paragraph 7, Section. 1 of the patent law - PG) or entry as a patented design (Paragraph 5, Section 4 of the patented design law - GMG).

## Safety Instructions

---

### 3 Safety Instructions

The usage of this coupling requires from the operator to observe all relevant industrial safety regulations. It is up to the duty of care of the user of the coupling to plan protective measures which guarantee an orderly operation and to control their realization.

 Danger references

In case of wrong product selection, inappropriate use and non-effected maintenance, there is a danger that damage can be caused to persons and objects. This may result from

- dangerous spreading of medium or individual particles / coupling parts.

 In particular, the operator must guarantee that

- coupling is always used according to specification.
- coupling is always used in an orderly, functionable way.
- operating instruction is always available to the operators in a complete and readable form.
- operating personnel is sufficiently informed about the operating and safety instructions of the coupling.
- for repair, couplings are returned to our factory.
- during operation of the coupling, no safety devices are removed and/or set out of function.
- coupling is not pressurized before mounting/dismounting of the coupling.

 The following items have to be observed after assembly and installation as well as before the first use of the coupling:

Check again whether all screw-type connections are firmly fixed.

Before the first use of the coupling, a functional test must be made (see "Maintenance and functional test").

#### 4 Warranty

The warranty conforms to:

the “General Conditions for Delivery and Capacity”  
of C.K. Walther GmbH & Co. KG  
of the state which was valid at the date of the purchase contract and

the regulations agreed in the purchase contract.

Wearing parts are generally excluded from the warranty.

Typical wearing parts of products from company C.K. Walther GmbH & Co. KG  
are for example:

- seals
- springs
- electric plug contacts
- electric cables and hoses which are exposed to a regular alternating bending load or torsional stress

Also components which normally do not wear under the estimated conditions (ambient and operational conditions) can transform into wearing parts if the described product is not operated to the agreed conditions or if technical demands of the operating instructions are disregarded.

Thus, for example electric cables are not part of this warranty if the coating is damaged by an extreme occurrence of flying welding sparks. Furthermore, the wear of other components which results from exceptional ambient conditions and which are not expressly agreed with C.K. Walther GmbH & Co. KG does not belong to this warranty such as high temperatures, abrasive acting dust, high humidity or corrosive acting steam and gases.

Regarding maintenance works, the demands dependent on cycles, time or load applications for the exchange of certain components of the described product are no warranty relevant statements of durability but recommendations for preventing maintenance for minimisation of standstill periods in production.

## General description of tool parking station Technical data

---

### **5 General description of tool parking station**

The tool parking station is used to pick up welding tools (welding guns) at robot working places with tool change systems.

The tool parking station can be modified for different requirements by the designed modular system and is adaptable to the tool geometry within limitations (see item 12).

The parking of the welding tools is done by vertical movement towards the parking position by the robot and disconnection of the tool changer.

The tools are parked in such a way, that tool side of the tool changer with parking segments which are provided with 2 bolts each is plunged in 2 sword guidances of the tool parking station. An additional support device (roll support) is not necessary for most of the applications.

According to scope of delivery and equipment the tool parking station consists of the following components:

- stand
- level adjustment
- support
- protection cover (hinged cover)
- installation package electro
- installation package pneumatic
- tool identification
- safety module

The stand and/or level adjustment are to be anchored in the floor of the hall and/or welded on a base plate by means of 4 screws M 16.

### **6 Technical data**

Main dimensions according to drawing (see item 12).

Support distance = 200 mm.

Tool clearance between the parking arms = 130 mm.

Interference dimension in parking direction = 0 ... 35 mm.

Maximum load = 6.000 N.

## Description of equipment

---

### **7 Description of equipment**

#### **7.1 Stand**

The stand consists of the welded bracket and the fastening elements.

##### Construction dimensions

- Height of parking station  
(clearance floor/tool changer – tool side – assembly side)
- Misalignment parking station/tool changer
- Drill picture base plate (attachment level adjustment  
Construction dimensions according to drawing (see item 12))

#### **7.2 Level adjustment**

The level adjustment is used to level the parking tool station (adjustment during installation).

Plate size = 400 mm x 500 mm  
Drill picture anchorage = 350 mm x 450 mm

#### **7.3 Support**

This component group takes up the torque caused by the tool load whereat two bolts of the tool changer each support themselves in horizontally and vertically displaced sword guidances which are arranged in a support distance of 200 mm.

With type 95813-Z01 a floated position with a radial balance of 1 mm is obtained.

Type 95813-Z02 is rigid piped.

#### **7.4 Protection cover**

Protection cover is used to avoid contaminations of tool changer parts being in the parking tool station, especially for protection against weld chips.

It is a pneumatic clamping unit with warm and cover and integrated position monitors.

- Air pressure connection  $p_{\min}$  = 5 bar.
- Aperture angle of protection cover = 90°.
- Proximity switch 1SE1R/2SE1R = "protection cover off".
- Proximity switch 1SE1V/2SE1V = "protection cover on".

If the cover is designed as flexible plastic plate (hardly flammable) the endangering is reduced by mobile parts to a large extent.

Weight: = kg (without valve and hoses)

#### **7.5 Installation package electro**

Depending on required scope of delivery:

- with Interbus module inclusive connector cable to sensors and valves.
- with Aktor sensor box inclusive connection cable to sensors and valves.

#### **7.6 Installation package pneumatic**

Depending on the required scope of delivery:

- with ISO pneumatic valve size 1 inclusive piping (without valve plug).



## Assembly and Installation

---

### 8 Assembly and installation

#### 8.1 General safety instructions

**ATTENTION!**

The tool parking station must not be used before the tool parking station is anchored in the floor of the hall, tipping danger!

**ATTENTION!**

Before connection to the air pressure system close cover!

Please observe safety distance to the moving parts during adjustment and operation!

#### 8.2 Erection

The tool parking station must be erected and adjusted in such a way that tool changer plate lies on horizontally. Maximum difference in height of support points = 1 mm.

Fastening is carried out in the floor of the hall with 4 anchor bolts M 16 or by welding on at an anchored steel base plate.

If delivery is carried out with level adjustment adjusting is essentially simplified:

- anchorage of the base plate in the floor of the hall.
- unscrew the 4 fillister head screws M 16 and groove nuts M 32x1.5.
- level the tool parking station by adjusting the 4 adjusting screws with wrench SW 36.
- fix the adjusting screws with the 4 groove nuts with sickle spanner DIN 1810-A45-50 (safety via Schnorr tooth lock washers).
- drive in the 4 fillister head screws M 16 with a hexagon screw driver SW 14. Torque = 195 Nm.

#### 8.3 Pneumatic installation

Version with protection cover only

a) Scope of delivery with installation package pneumatic:

Pneumatic installation is complete; the protection cover movement is adjusted.

Air pressure connection is carried out according to pneumatic schedule (see 12) at the connecting plate of the ISO directional control valve.

Please observe safety instructions to item 7.1!

b) Scope of delivery without installation pneumatic:

- mount the directional control valve at the rear side of the parking station bracket.
- screw in swivel connections with one-way restrictor into the pneumatic cylinder and complete closing of the chokes by clockwise turning of the adjusting screw.
- Installation of hose connections between cylinder and directional control valve.
- screw in sound absorbers.
- air pressure connection see A.
- adjust protection cover movement by careful unscrewing of the adjusting screws of the chokes (tipp operation for valve circuit).

## Assembly and Installation

---

**ATTENTION!**

**Avoid hard final position stress!**

**ATTENTION!**

**Do not operate pneumatic cylinder of the protection cover without choke!**

**ATTENTION!**

**Opening of the protection cover is done due to pressure build-up with a delay of 1 ... 2 s !**

### **8.4 Electrical installation**

- a) Scope of delivery without installation package electro:
  - adjust the signalling point of the proximity switch.
  
- b) Scope of delivery with installation package electro (Aktor-Sensor-Box/ Distributor):
  - The electro installation is complete; the signalling point of the proximity switch is adjusted.
  - The control connection is done according to customer`s control via the plug connection at the Aktor-Sensor-Box/distributor.
  - Check signalling point of the proximity switch, readjust if necessary.
  
- c) Scope of delivery with installation package electro (Interbus module):
  - The electro installation is complete; the signalling point of the proximity switch is adjusted.
  - Incoming and continuing signal cable are plugged in via the plug connection of the BUS module according to customer`s control.
  - check signalling point of the proximity switch, readjust if necessary.

## Comments to application preparation

---

### **9 Comments to application preparation**

Adjust the signalling point of the proximity switch.

The tool parking station must stand within the working area of the robot to enable a direct parking of the tool.

To avoid that the tool (tool changer) falls out of the receptacles the mass center of gravity of the tool must be within the extension of the support width. As the distance of the locating bolt is 200 mm, a position of the center of gravity within an area of 150 mm is regarded as safe (75 mm from the center line).

The parking of tools into the tool parking station as well as the picking up of tools from the tool parking station is done fully automatically by the robot. The opening of the protection cover before the tool is picked up and the closing of the protection cover after the tool is picked up is robot controlled.

Flow chart see documentation of the tool changer.

When parking the tool strong shock loads caused by too high disconnecting speed of the tool changer or the free fall of the load are to be avoided!

Please observe a sufficiently great distance to interference contours when lifting the tool/tool changer out of the tool parking station!

The insertion depth of the guiding bolts is 30 mm so that before an extension movement taking place radial to the robot axis 6 the tool side of the tool changer must be lifted by at least 35 mm

In case of mounted tool please observe that the tool during this extension movement does not collide with the holding device (Rob-CAD-test).

## Commissioning, working and maintenance

---

### **10 Commissioning, working and maintenance**

#### **10.1 General safety instructions**

- Prior to commissioning check the anchorage in the floor of the hall on its interference fit!
- Keep away parts of the body especially hands from the hinged cover mechanism during automatic and hand operation, danger of injury!

#### **10.2 Preventive checks**

WALTHER tool parking stations are to be operated in such a way that external damages especially all moving parts are excluded.

According to our practical experience tool parking stations will give long-term, trouble free service if care is taken to recognize and repair any possible damages in good time.

Preventive visual checks are to be carried out once a week or after 10,000 couple cycles each.

- Please observe the interference fit of all screwed cable glands!
- Check the welding construction of the stand on cracks and deformations!
- Check the hinged mechanism of the protection cover for ease of movement and deformations!
- Check the signalling point of the proximity switch!

#### **10.3 Maintenance**

To reduce connecting forces of the tool changer to a minimum and to prolong lifetime the following parts must be slightly greased:

- sword guidances.
- all hinged parts at the pneumatic clamping unit.

Use greases (e.g. Arcanol Multi 3) and contact sprays which do not attack the mounted FKM seals and meet the requested cleanliness requirements (observe internal instructions).

Recommended maintenance cycle:

once a week or after 10,000 couple cycles each.

## Works on malfunctions and damages

---

### 11 Works on malfunctions and damages

#### 11.1 General safety instructions

Works on tool parking stations shall only be carried out

- if **no** tool is in the parking station.
- **without pressure (in case of version with protection cover).**
- **if the robot was moved into a safe position and stopped.**

#### 11.2 Malfunctions and assessment of damage

Malfunctions can only arise by:

- failure at the proximity switches/ connecting pieces/BUS or distribution modules.
- failure at the pneumatic components.
- mechanical deformation/cracks at the stand, support, protection cover owing to a crash or overload and/or use not in accordance with the requirements.
- wear at the bearing places by insufficient lubrication.

The main function dimensions must be checked after a crash especially the distance dimension of the sword guidances =  $200^{\pm 0,2}$  mm.

In case of smaller deformations it can be readjusted. If it concerns larger damages the defect parts are to be replaced by new ones..

**Attention!**

**After a crash check fastening / anchorage at the floor of the hall!**

#### 11.3 Repair

Faulty electrical or pneumatic components are to be replaced. The signalling point of the proximity switches is to be readjusted.

The tool parking station must be readjusted and levelled after a repair (straighten or exchange stand parts).

If necessary the robot aim positions are to be programmed once again.

**Attention!**

**Close cap of the protection cover prior to reoperation and/or connection to the air pressure system. After the exchange of pneumatic cylinder or one way restrictors the cap speed must be readjusted.**

12 Drawings and parts lists

## Drawings and parts lists

---

12.1 1-95813-9-00034-AAAA-Z03  
parking station

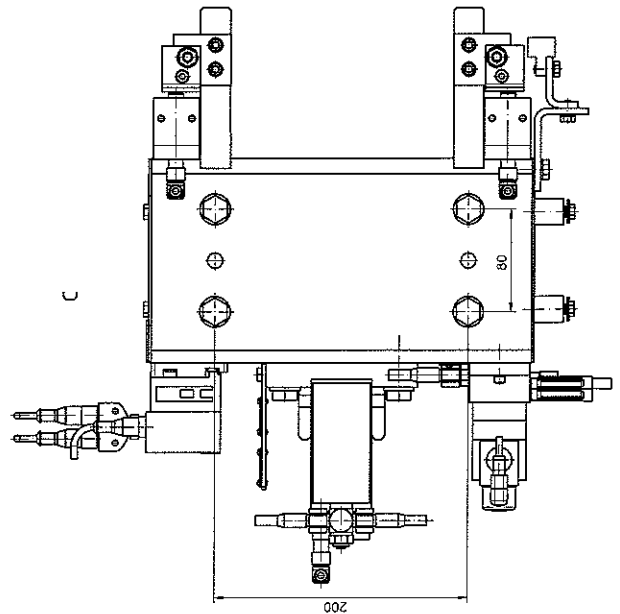
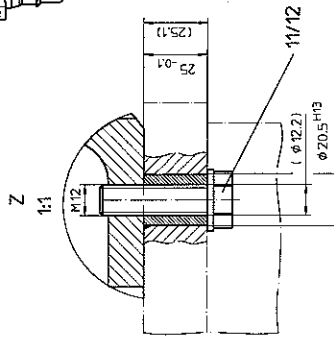
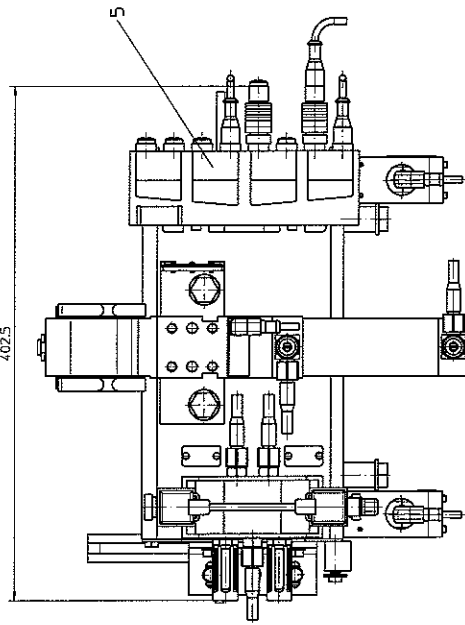
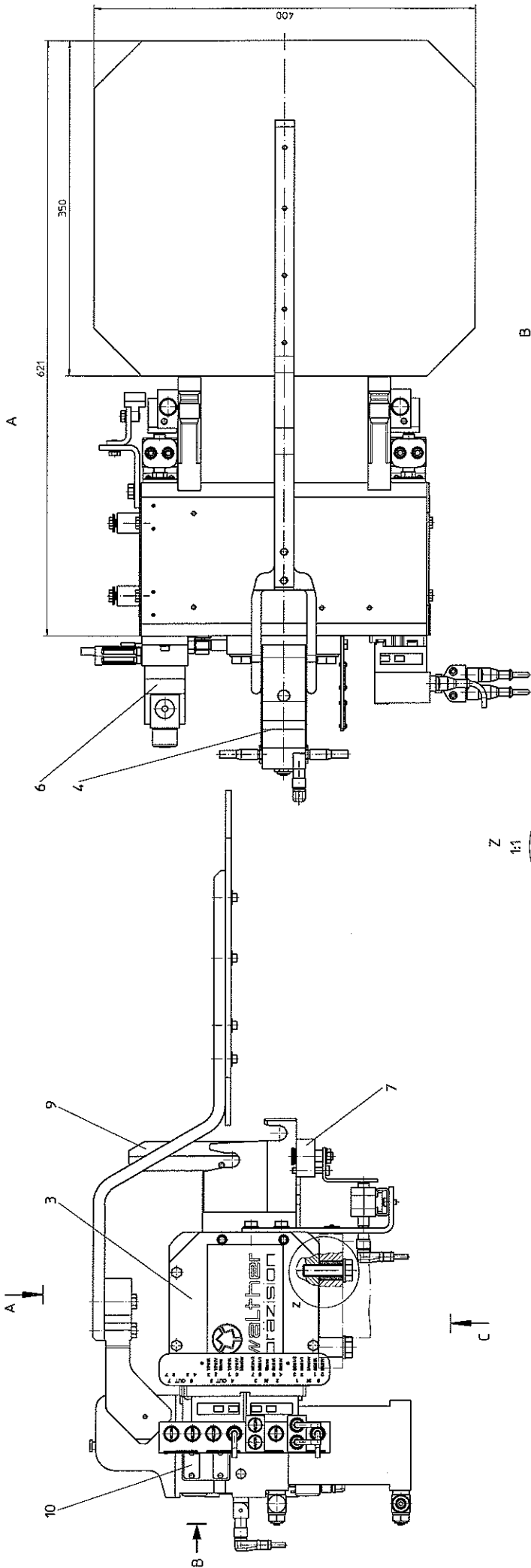

Maße siehe auch Gestellanschnittstelle für Ablagenkopf  
 For further measurings look at frame interface for parking heads  
 1-95813-D-00002

<b>Walthers Präzision</b>		1-95813-9-00034-...-Z03	
Formel-Nr.	1-2	Erstellt für	
Erstellt für	Austführung: A	Erstellt am	2007/04/19 TG
Werkstoff-Nr.	VOIT	Geprüft	2007/04/19 TG
Erstellt am		Geprüft	2007/04/19 RN
Erstellt am		Geprüft	2007/04/19 RN
EAD-Zeichnung nur auf 3D-Systeme anwenden!			
Walthers Präzision GmbH, Postfach 101, D-42699 Solingen			
K D-65		PT	2223
Werkzeugablage Kopf - Master parking station head - master			



Pos.	Benennung	Identnr.	Zeichnungsnr.	Stueck	Werkstoff/Werkstoffnr.	Bemerkung
03	ABSTÜTZUNG	76964	1-95813-B-00003-AAAA-Z03	1.000		
04	KLAPPDECKEL-ABDECKUNG/LWL	82944	1-95813-B-00008-AAAA-Z03	1.000		
05	Installationspaket Elektro	106080	1-95813-E-00008-AAAA-Z03	1.000		
06	Installationspaket Pneumatik	101807	1-95813-P-00007-AAAA-Z03	1.000		
07	WERKZEUGKENNUNG	76979	1-95813-B-00005-AAAA-Z03	1.000		
09	SICHERHEITSMODUL (ABLAGE)	76982	1-95813-B-00006-AAAA-Z03	1.000		Firmenschild Typenschild
10	BESCHRIFTUNG	42517	1-95813-B-00016-AAAA-Z03	1.000		
11	SECHSKANTSCHRAUBE	3670	DIN 933-M12 X 45- 8.8	4.000	STAHL	
12	SCHEIBE	1182	DIN 125-A 13 -ST	4.000	STAHL	

Die Zeichnung ist unser Eigentum. Jede Vervielfältigung, Verwertung oder Mitteilung an dritte Personen ist daher strafbar und wird gerichtlich verfolgt. (Urheberrechtsgesetz, Gesetz gegen unlauteren Wettbewerb, BGB). Alle Rechte für den Fall der Patenterteilung (§7 Abs.1 PG) oder GM-Eintragung (§5 Abs.4 GMG) vorbehalten.

	Ausf.: A vom 16.04.2007		Werkzeugablage Kopf - Master	
	A200753			
	Ersterst.	Datum	Name	
	Geschr.	16.04.2007	TGrah	
Geprüft	19.04.2007	TGrah	Bestellnummer:	Sachnummer:
	19.04.2007	AHeinemann	1-95813-9-00034-AAAA-Z03	106082

## Drawings and parts lists

---

- 12.2 1-95813-B-00003-AAAA-Z03  
Support for welding guns  
1-95813-B-00024-AAAA-Z03 group zero-sockets

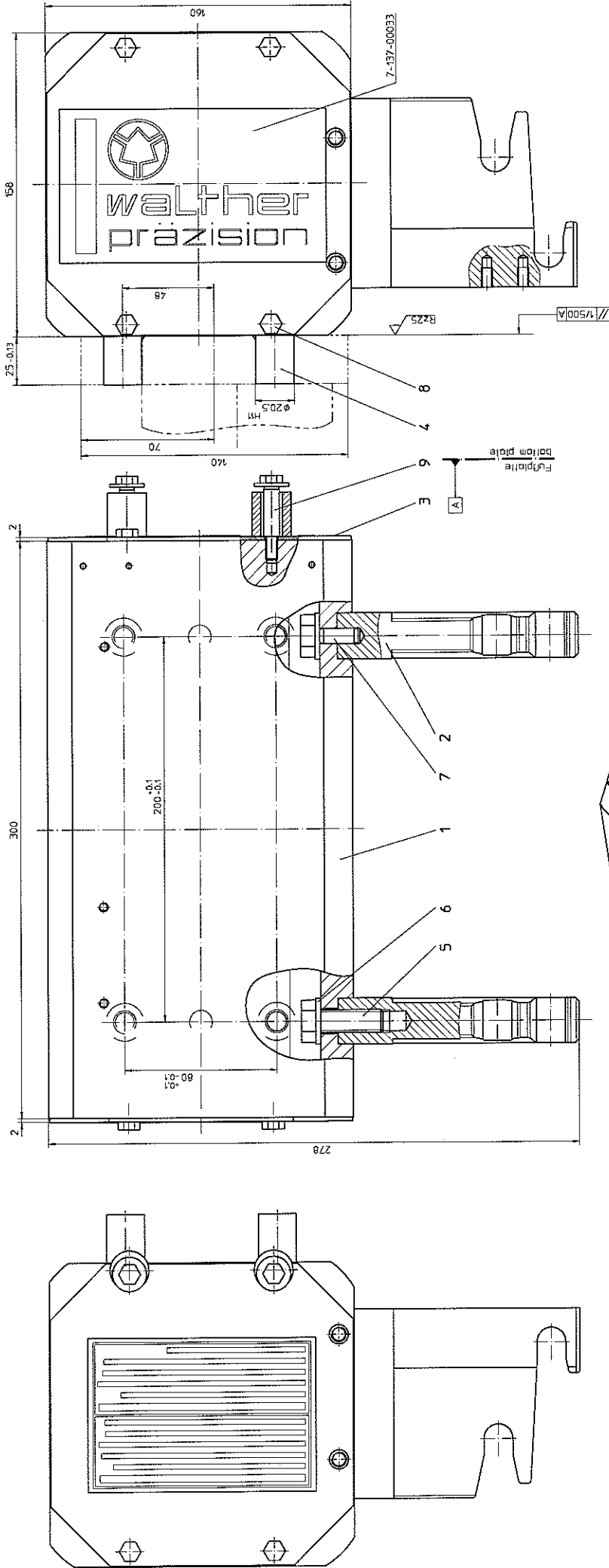

**Einrichtung Nullbuchen 1-95813-B-00024-...-Z03**  
 Zur Einrichtung der Roboterkopf 2 Nullbuchen (rot) diagonal montieren.  
 Dazu am Ablegekopf 2 Sechskantschrauben M12 diagonal gegenüber lösen.  
 Original-Distanzbuchen durch die 2 Nullbuchen ersetzen und festschrauben.  
 Sofort nach dem Einrichten die Nullbuchen wieder demontieren, und durch  
 Original-Distanzbuchen ersetzen, um schwimmende Lagerung herzustellen !  
**Instruction for zero-sockets 1-95813-B-00024-...-Z03**  
 For teach-in the robot course install diagonally 2 zero-sockets (red).  
 Thereby loose diagonally opposite 2 hexagon screws M12 at the parking head.  
 Replace originally spacer sockets by the 2 zero-sockets and screw down.  
 Instantaneously after teach-in zero-sockets strip and replace them by the  
 originally spacer sockets to provide floating support.

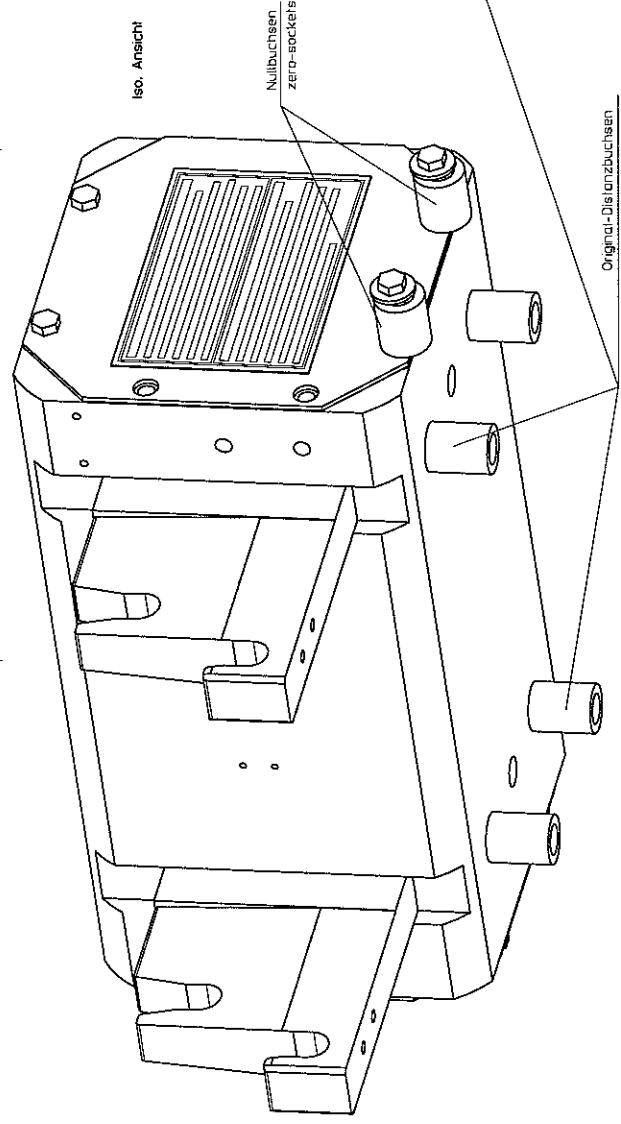

		<b>1-95813-B-00003-...-Z03</b>	
Fertigungs- und Prüfrichtlinien nach MAL High Precision	Ausführung: H	Datum: 2006/02/06	Name: TG
Zeichnung Nr.: 210003	A: 100354	Gezeichnet: 2006/02/06	TG
CAD-Zeichnung nur mit 3D-Systeme öffnen !	A: 100354	Geprüft: 2006/02/06	RN
Datum: 2006/02/06	Gezeichnet: 2006/02/06	Geprüft: 2006/02/06	RN
K	ID-CB	PT	Abstützung Support for welding guns

Pos.	Benennung	Identnr.	Zeichnungsnr.	Stueck	Werkstoff/Werkstoffnr.	Bemerkung
1	Grundkörper	76965	4-95813-503-11-Z03	1.0000	1.0570/1.003	
2	Aufnahme	76966	4-95813-504-00-Z03	2.0000	1.2311 V	
3	Deckel	76967	4-95813-505-11-Z03	2.0000	1.0570/1.003	
4	Distanzbuchse	76968	4-95813-513-11-Z03	4.0000	9SMNFB28K 1.0718K	
5	SECHSKANTSCHRAUBE	77113	DIN 933-M12 X 35-10.9	4.0000	STAHL	
6	SCHEIBE	1182	DIN 125-A 13-ST	4.0000	STAHL	
7	Spannstift	73923	DIN 1481-8 X 20-A2	2.0000	X8CrNiS18-9 1.4305	
8	SECHSKANTSCHRAUBE	3428	DIN 933-M 6 X 10-A2-70	6.0000	X10CRNiS18 9 1.4305	
09	Gruppe Nullbuchse	99891	1-95813-B-00024-AAAA-Z03	1.0000		2 Stk. Nullbuchse 4-95499-509 lose beigeigt und nach dem Ausrichten,beim Kunden,entfernt Aufkleber 7-137-00033

Die Zeichnung ist unser Eigentum. Jede Vervielfältigung, Verwertung oder Mitteilung an dritte Personen ist daher strafbar und wird gerichtlich verfolgt. (Urheberrechtsgesetz, Gesetz gegen unlauteren Wettbewerb, BGB). Alle Rechte für den Fall der Patenterteilung (§7 Abs.1 PG) oder GM-Eintragung (§5 Abs.4 GMG) vorbehalten.

	Ausf.: D vom 22.01.2007		ABSTÜTZUNG  Bestellnummer: <b>1-95813-B-00003-AAAA-Z03</b>	Sachnummer: <b>76964</b>	
	A200468				
	Ersterst.	Datum			Name
	Geschr.	30.11.2006			GNeschen
Geprüft.	30.11.2006	MHerold			

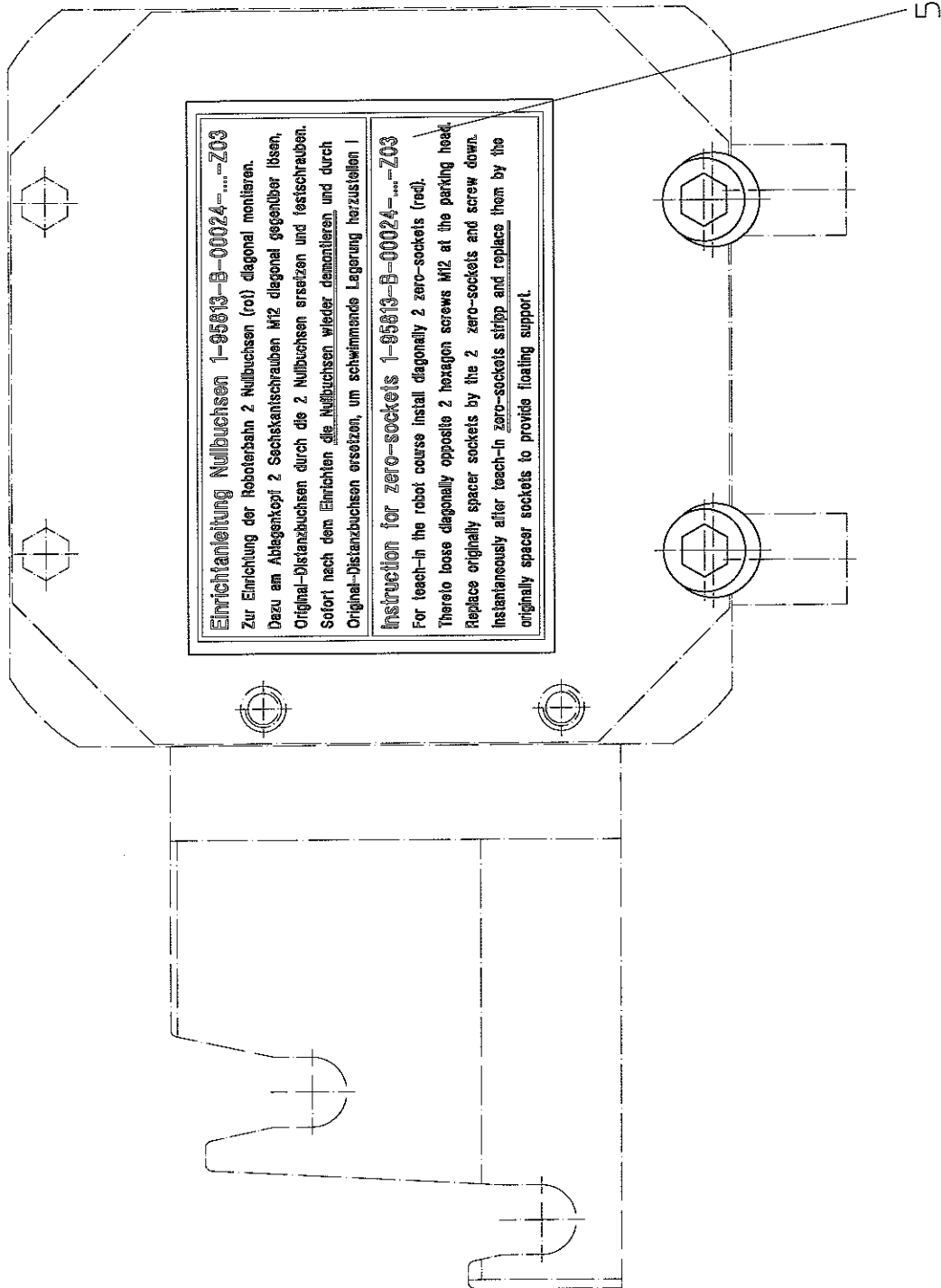

**Einrichtung Nullbuchen 1-95813-B-00024-...-Z03**  
 Zur Einrichtung der Roboterbahn 2 Nullbuchen (rot) diagonal montieren.  
 Dazu am Ablagekegel 2 Sechskantschrauben M12 diagonal gegenüber lösen.  
 Original-Distanzbuchsen durch die 2 Nullbuchen ersetzen und festschrauben.  
 Sofort nach dem Einrichten die Nullbuchen wieder demontieren und durch  
 Original-Distanzbuchsen ersetzen, um schwimmende Lagerung herzustellen !

**Instruction for zero-sockets 1-95813-B-00024-...-Z03**  
 For teach-in the robot course install diagonally 2 zero-sockets (red).  
 There to loose diagonally opposite 2 hexagon screws M12 at the parking head.  
 Replace originally spacer sockets by the 2 zero-sockets and screw down.  
 Instantaneously after teach-in zero-sockets strip and replaces them by the  
 originally spacer sockets to provide floating support.

**walther**  
**präzision**

Die Zeichnung ist unserer Eigentum.  
 Jede Vervielfältigung, Verwehung  
 ohne Mitteilung an diese Person  
 ist strafbar und wird gesetzlich  
 verfolgt.  
 Verlags: Druckerei  
 Weibowen, 8200. Alle Rechte für  
 das Jahr der Patentierung  
 Paragraph 7 Abs. 1 PatG oder Bk-  
 Eintragung, Paragraph 5 Abs. 2  
 SGG vorbehalten.

**K D-GB** **PT**  
**7022**

1-95813-B-00024-...-Z03		Ersatz für:		Name	
Maßstab: 1:1	Fertigungs- und Prüfvorschriften nach WALTHER	Ausführung: A	Erstverleig: 2005/02/06	Datum	TG
	Werknorm-Nr.: 12100.03	VOM: A	Gezeichnet: 2006/02/06	Geprüft: 2006/02/07	TG
				Ä-geprüft: 2006/02/07	RN
CAD-Zeichnung nur mit 3D-System ändern !					
Gruppe Nullbuchen group zero-sockets					

Pos.	Benennung	Identnr.	Zeichnungsnr.	Stueck	Werkstoff/Werkstoffnr.	Bemerkung
01	Nullbuchse	87737	4-95499-509-36	2.0000	AlMgSi1 F28 3.2315.71	
2	Sechssakantschraube	99855	DIN 933-M 6 X 40- 8.8	2.0000	STAHL 8.8	
3	Scheibe	1191	DIN 9021-6,4-ST	2.0000	STAHL	
4	Spannstift	99856	DIN 7346- 8 X 26-FST	2.0000	FST	
5	Aufkleber Nullbuchsenanleitung	99854	7-137-00041	1.0000	PVC PVC	

Die Zeichnung ist unser Eigentum. Jede Vervielfältigung, Verwertung oder Mitteilung an dritte Personen ist daher strafbar und wird gerichtlich verfolgt. (Urheberrechtsgesetz, Gesetz gegen unlauteren Wettbewerb, BGB). Alle Rechte für den Fall der Patenterteilung (§7 Abs.1 PG) oder GM-Eintragung (§5 Abs.4 GMG) vorbehalten.

		Ausf.: <b>B</b> vom <b>30.11.2006</b>													
		<b>A200361</b>													
<table border="1"> <tr> <td>Ersterst.</td> <td>30.11.2006</td> <td>Name</td> <td>GNeschen</td> </tr> <tr> <td>Geschr.</td> <td>30.11.2006</td> <td>GNeschen</td> <td></td> </tr> <tr> <td>Geprüft.</td> <td>30.11.2006</td> <td>MHerold</td> <td></td> </tr> </table>	Ersterst.	30.11.2006	Name	GNeschen	Geschr.	30.11.2006	GNeschen		Geprüft.	30.11.2006	MHerold		Gruppe Nullbuchse		
	Ersterst.	30.11.2006	Name	GNeschen											
	Geschr.	30.11.2006	GNeschen												
Geprüft.	30.11.2006	MHerold													
Sachnummer: <b>99891</b>			Bestellnummer: <b>1-95813-B-00024-AAAA-Z03</b>												

## Drawings and parts lists

---

12.3 1-95813-B-00008-AAAA-Z03  
Hinged cover

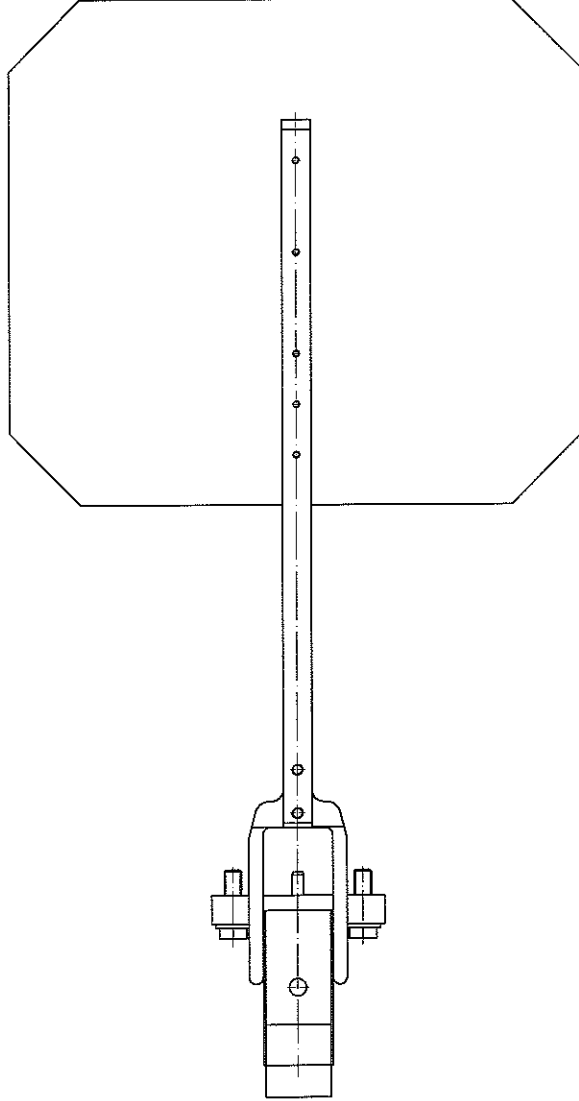
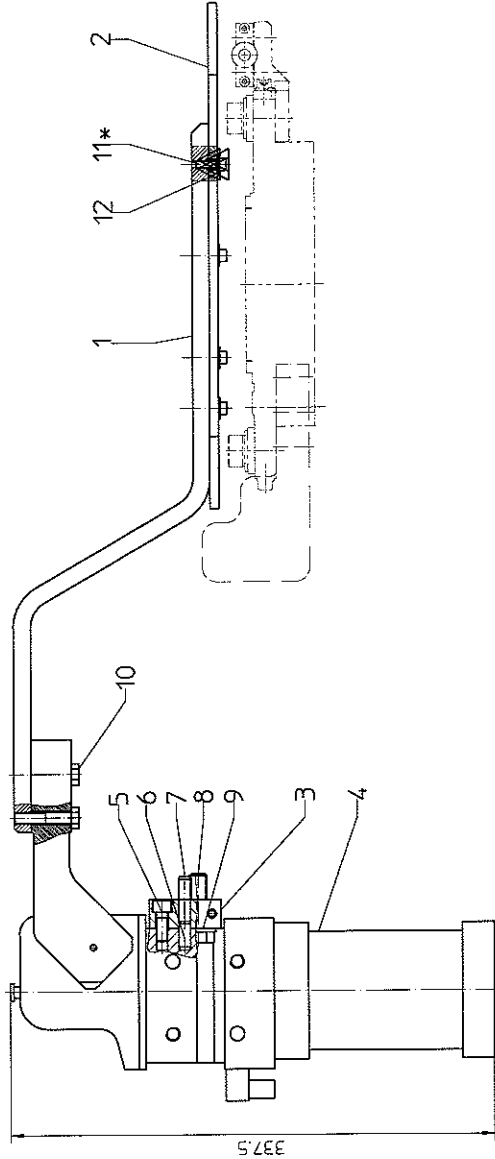
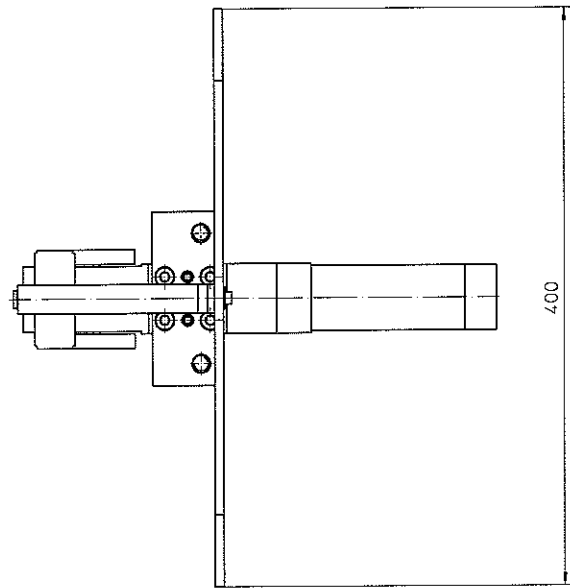

\* mit Loctite gesichert  
 \* secured with Loctite

**walther**  
 präzision

Das Unternehmen Walther Präzision ist ein führender Hersteller von Präzisionswerkzeugen mit 70 Jahren Erfahrung. Die Produkte sind weltweit bekannt und werden in über 100 Ländern eingesetzt. Die Produkte sind in den Bereichen Industrie, Handwerk, Landwirtschaft, Luftfahrt, Raumfahrt, Medizin, etc. eingesetzt. Die Produkte sind in den Bereichen Industrie, Handwerk, Landwirtschaft, Luftfahrt, Raumfahrt, Medizin, etc. eingesetzt. Die Produkte sind in den Bereichen Industrie, Handwerk, Landwirtschaft, Luftfahrt, Raumfahrt, Medizin, etc. eingesetzt.

1-95813-B-00008-.....Z03		Erstellt für:		Name	
Verfärb. 1:2.5		Ausführung: E		Datum	
Prüfverfahren nach WALTHER		Vom: 2004/08/16 JP		Erstbearbeitung: 2003/09/22 AM	
Werkstoff-Nr.: 42100.03		A 09607		Gezeichnet: 2003/09/09 AM	
CAD-Zeichnung nur mit 3D-Systeme öffnen!		A-gespeich.		Geprüft: 2003/09/18 KHK	
				K-gespeich.: 2004/08/17 KHK	
Klappdeckel - Abdeckung/LWL Hinged cover					
K D-GB		PT			



Pos.	Benennung	Identnr.	Zeichnungsnr.	Stueck	Werkstoff/Werkstoffnr.	Bemerkung
1	Arm	76970	4-95813-506-11-Z03	1.0000	SI37-2 1.0037	
2	Deckel	81707	4-95813-518-00-Z03	1.0000	RECA-PUR GELB	
3	Adapterplatte	76971	4-95813-507-11-Z03	1.0000	ST37.2 1.0037K	
4	KOMPAKTSpanner MIT SELBSTHALT.	72299	7-129-K50 T12 A10 90	1.0000		Fa. TÜNKERS (VW Ausführung) oder Kundenbestellung
5	ZYLINDERSCHRAUBE	3185	DIN 912-M 8X X 20-A2-70	4.0000	X10CRNiS18 9 1.4305	
6	Spannstift	73923	DIN 1481- 8 X 20-A2	2.0000	X8CrNiS18-9 1.4305	
7	SPANNSTIFT	73922	DIN 1481- 8 X 24-A2	1.0000	X10CRNiS18 9 1.4305	
8	SECHSKANTSCHRAUBE	77121	DIN 933-M12 X 40-10.9	2.0000	STAHL	
9	SCHEIBE	1182	DIN 125-A 13 -ST	2.0000	STAHL	
10	SECHSKANTSCHRAUBE	19798	DIN 931-M 8 X 40-A2-70	2.0000	X10CRNiS18 9 1.4305	
11	ZYLINDERSCHRAUBE	19664	DIN 912-M 5X X 16-A2-70	4.0000	X10CRNiS18 9 1.4305	

Die Zeichnung ist unser Eigentum. Jede Vervielfältigung, Verwertung oder Mitteilung an dritte Personen ist daher strafbar und wird gerichtlich verfolgt. (Urheberrechtsgesetz, Gesetz gegen unlauteren Wettbewerb, BGB). Alle Rechte für den Fall der Patenterteilung (§7 Abs.1 PG) oder GM-Eintragung (§5 Abs.4 GMG) vorbehalten.

	Ausf.: B vom 22.01.2007		KLAPPDECKEL-ABDECKUNG/LWL	
	A200464			
	Ersterst.	Datum		Name
	Geschr.	Geprüft.		AHeinemann
Bestellungsnr. <b>1-95813-B-00008-AAAA-Z03</b>			Sachnummer: <b>82944</b>	

Pos.	Benennung	Identnr.	Zeichnungsnr.	Stueck	Werkstoff/Werkstoffnr.	Bemerkung
12	SCHEIBE	1431	DIN 9021- 5,3-A4	4.0000	X6CRNiMoTi17 12 2 1.4571	

Die Zeichnung ist unser Eigentum. Jede Vervielfältigung, Verwertung oder Mitteilung an dritte Personen ist daher strafbar und wird gerichtlich verfolgt. (Urheberrechtsgesetz, Gesetz gegen unlauteren Wettbewerb, BGB). Alle Rechte für den Fall der Patenterteilung (§7 Abs.1 PG) oder GM-Eintragung (§5 Abs.4 GMG) vorbehalten.

		Ausf.: B vom 22.01.2007	
		A200464	
Ersterst.	Datum	Name	KLAPPDECKEL-ABDECKUNG/LWL
Geschr.	22.01.2007	GNeschen	
Geprüft.	22.01.2007	GNeschen	
Bestellnummer:			Sachnummer:
1-95813-B-00008-AAAA-Z03			82944
		22.01.2007	

12.4 1-95813-E-00008-AAAA-Z03  
electrical equipment

1-95813-E-00009-...-Z03

Slave-Ablage  
Slave parking station

\*Bei Slave anschluss entfernt.  
\*Removed when slave mounted.

Werkzeugablage Slave  
Kabel nicht im Lieferumfang!  
parking station slave  
Cables not in scope of delivery

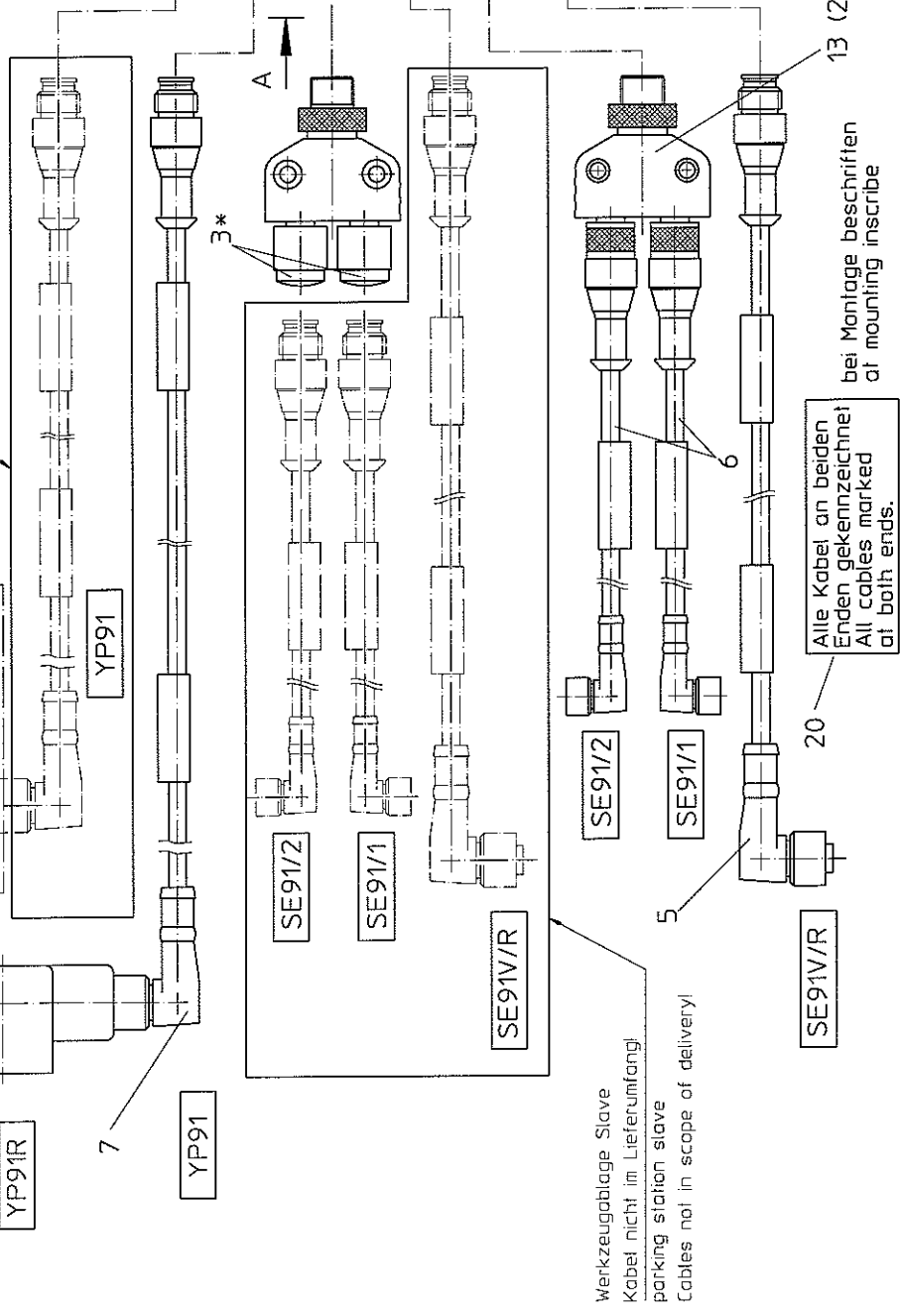
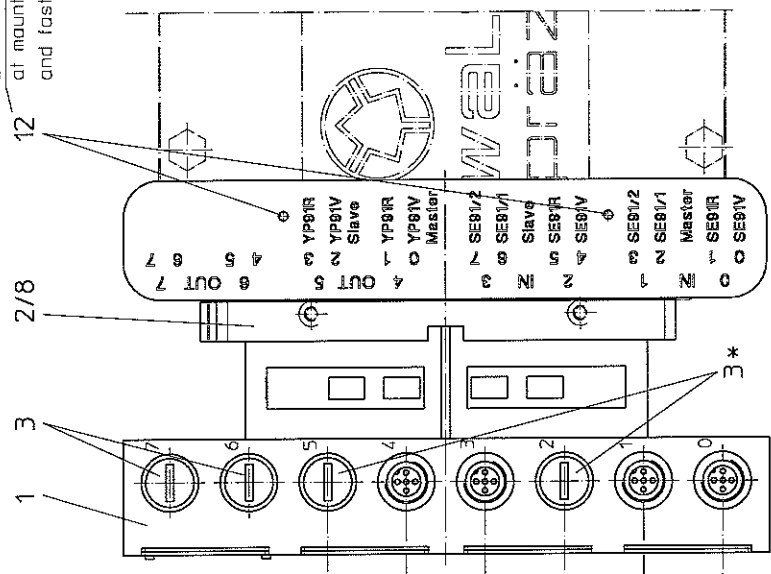
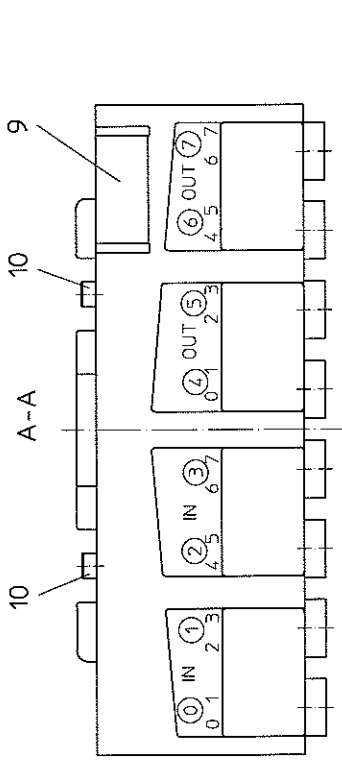
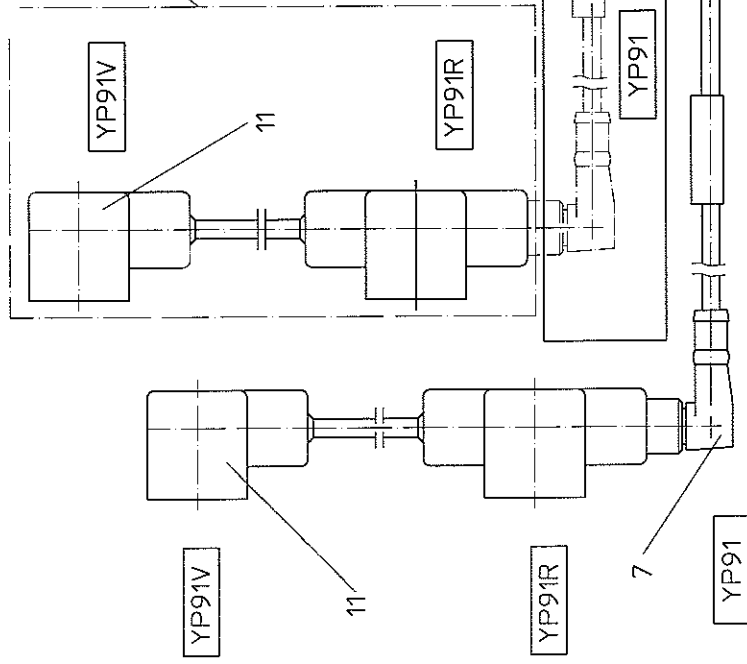

Werkzeugablage Slave  
Kabel nicht im Lieferumfang!  
parking station slave  
Cables not in scope of delivery

Alle Kabel an beiden  
Enden gekennzeichnet!  
All cables marked  
at both ends.

bei Montage beschriften  
at mounting inscribe

1-95813-E-00008-...-Z03		1-95813-E-00009-...-Z03	
Material: 1:1 Ersatz für:		Ersatz für:	
Fertigungs- und Prüfvorschriften nach WALZER vom:		Ausführung: A	
Werkzeug-Nr. 12100.03		A	
CAD-Zeichnung nur als 3D-System ändern		Gezeichnet: 2007/04/19	
		Geprüft: 2007/04/19	
		Kassiert: 2007/04/19	
		Name Datum	
		Erstellt: 2004/04/17 TG	
		Gezeichnet: 2007/04/19 TG	
		Geprüft: 2007/04/19 RN	
		Kassiert: 2007/04/19 RN	
Installationspaket Elektro		electrical equipment	
K	D-GB	PT	7/23

Die Zeichnung ist unter Eigentum der Walther-Präzision zu verstehen. Die Weitergabe der Zeichnung ist ohne schriftliche Genehmigung der Walther-Präzision ist untersagt. Die Rechte für den Fall der Patentverletzung der Walther-Präzision sind vorbehalten.

Pos.	Benennung	Identnr.	Zeichnungsnr.	Stueck	Werkstoff/Werkstoffnr.	Bemerkung
01	RUGGED LINE (INTERBUS)	39859	7-217-IBS RL 24 DIO 8/8-RLK	1.0000		
02	MONTAGEPLATTE	78920	7-217-IBS RL AP	1.0000		
03	Schutzkappe	61976	7-054-IBS IP PROT IO	6.0000		
05	Verbindungskabel	39884	7-113-RST5-RKWT-LED P5 181	1.0000		
06	Verbindungskabel	39884	7-113-RST5-RKWT-LED P5 181	2.0000		
07	Verbindungskabel	39884	7-113-RST5-RKWT-LED P5 181	1.0000		
08	ZYLINDERSCHRAUBE	4629	DIN 84-M 4 X12-A2-70	4.0000	X10CRNIS18 9 1.4305	
09	Beschriftungsschild	84155	7-137-IBS RL MARKER-SET-KLEIN	2.0000		
10	ZYLINDERSCHRAUBE	1017	DIN 912-M 4X X 10-A2-70	2.0000	X10CRNIS18 9 1.4305	
11	Anschlußleitung Doppelmagnetv.	41025	7-113-VAS22-2.048-0,4-VZSA22-2.048-F	1.0000		
12	BLINDNIETE	65755	DIN 7337-A 2,4 X 8	2.0000		
13	BLOCKVERTEILER 2FACH	72744	7-217-FSM5-2 FKM5.4/S89	2.0000		
20	Kennzeichnungsschild	47947	7-137-7723-ELOX	10.0000	AL	
21	Kennzeichnungsschild	106081	4-91489-574-31AD-00001-Y10	1.0000	AlMgSi1 F28 3.2315.71	

Die Zeichnung ist unser Eigentum. Jede Vervielfältigung, Verwertung oder Mitteilung an dritte Personen ist daher strafbar und wird gerichtlich verfolgt. (Urheberrechtsgesetz, Gesetz gegen unlauteren Wettbewerb, BGB). Alle Rechte für den Fall der Patenterteilung (§7 Abs.1 PG) oder GM-Eintragung (§5 Abs.4 GMG) vorbehalten.

Ausf.: A vom 16.04.2007		Installationspaket Elektro	
<b>A200753</b>			
	Datum	Name	
Erstest.	16.04.2007	TGrah	
Geschr.	19.04.2007	TGrah	
Geprüft	19.04.2007	AHeinemann	
Bestellnummer. <b>1-95813-E-00008-AAAA-Z03</b>			Sachnummer. <b>106080</b>

12.5 1-95813-P-00007-AAAA-Z03  
Installationspaket Pneumatik

geöffnet  
open

Abdeckklappe  
cover

geschlossen  
closed

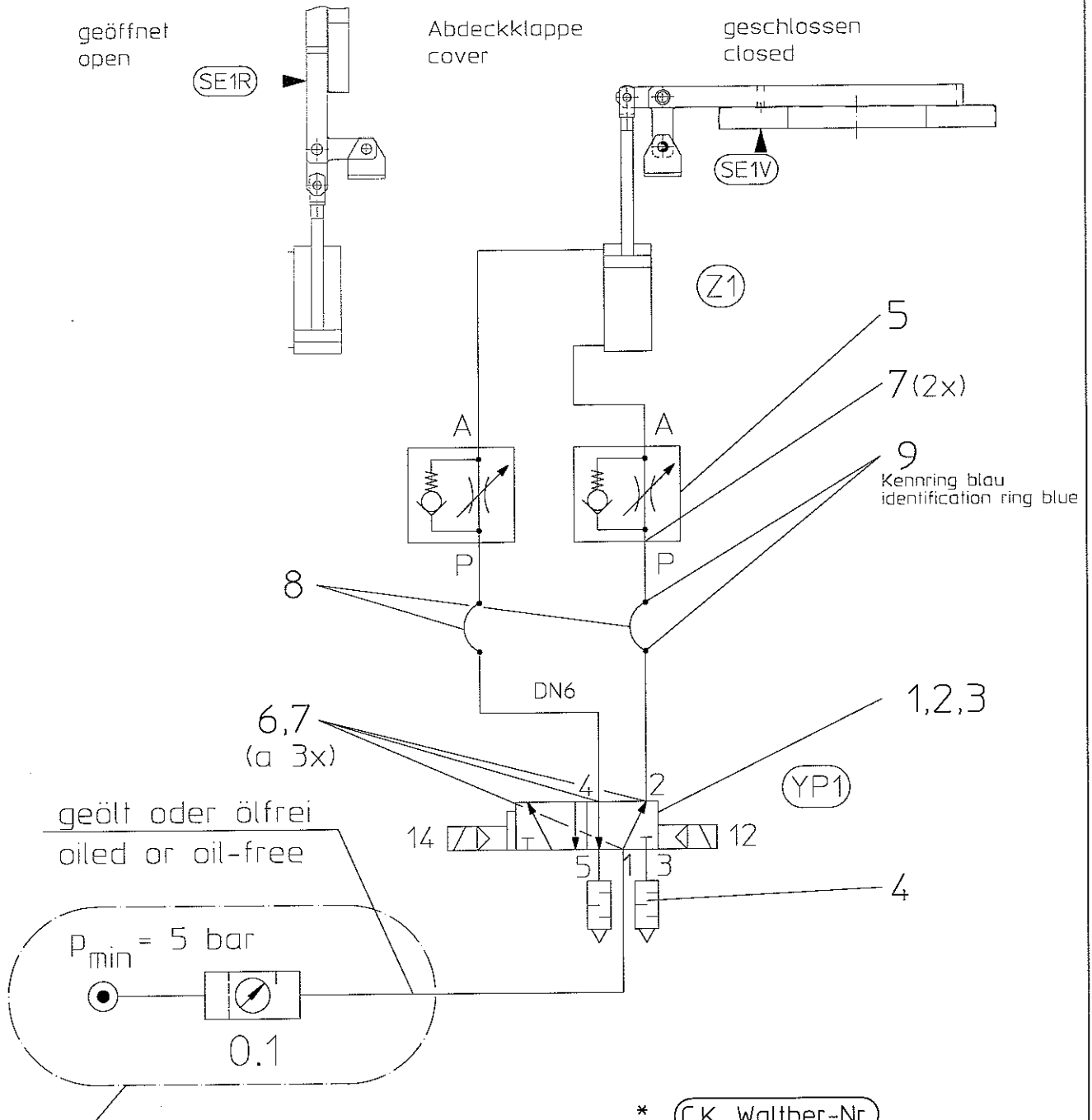

Nicht im Lieferumfang!  
Not in scope of delivery  
Lieferumfang nach Stückliste  
Scope of delivery as per parts list

\* **C.K. Walther-Nr.**  
\* Festlegung der Funktionsbezeichnung erfolgt bei E-Plan-Aufnahme!  
Definition of the function description is carried out when preparing the E-plan!



Die Zeichnung ist unser Eigentum. Jede Vervielfältigung, Verwertung oder Mitteilung an dritte Personen ist strafbar und wird gerichtlich verfolgt (Urheberrechtsgesetz, Gesetz gegen unlauteren Wettbewerb, BGG). Alle Rechte für den Fall der Patenterteilung (Paragraph 7 Abs. 1 PG) oder GM-Eintragung (Paragraph 5 Abs. 4 GMG) vorbehalten.

1-95813-P-00007-...-Z03

Maßstab:	Ersatz für:		Datum	Name
Fertigungs- und Prüfvorschriften nach WALTHER	Ausführung: A	Erstellt	2006/06/12	TG
Werknorm-Nr.: 121.00.03	vom: 2006/06/12 TG	Gezeichnet	2006/06/12	TG
	A 100787	Geprüft	2006/06/12	RN
CAD-Zeichnung nur mit 2D-System ändern !		Ä-geprüft	2006/06/12	RN

Installationspaket Pneumatik  
pneumatical equipment

K D-GB

Pos.	Benennung	Identnr.	Zeichnungsnr.	Stueck	Werkstoff/Werkstoffnr.	Bemerkung
1	Wegeventil	42549	7-092-00.100 44	1.000		
2	ZYLINDERSCHRAUBE	19664	DIN 912-M 5X X 16-A2-70	2.000	X10CRNIS18 9 1.4305	
3	SCHEIBE	1427	DIN 125-A 5,3-A2	2.000	X10CRNIS18 9 1.4305	
4	Schalldämpfer	89331	7-039-U-1/4-B	2.000		
5	Schwenkanschluss	62594	7-116-SA 816/00	2.000		
6	Schlauchtülle	62610	7-207-VW 39-V-16631	5.000	1.4305	
7	Doppelnippel	62702	7-079-39 D 1403/1	3.000		
8	Steckschlauch	62539	7-027-VW 39-V-16662 NW 6	4.000	NEOPRENE M.TEXTILE.	4 Stück a 0,4 Meter
9	Kabelbinder	83782	7-048-VB50-204 X 4,7	2.000	PA 6.6	

Die Zeichnung ist unser Eigentum. Jede Vervielfältigung, Verwertung oder Mitteilung an dritte Personen ist daher strafbar und wird gerichtlich verfolgt. (Urheberrechtsgesetz, Gesetz gegen unlauteren Wettbewerb, BGB). Alle Rechte für den Fall der Patenterteilung (§7 Abs. 1 PG) oder GM-Eintragung (§5 Abs. 4 GMG) vorbehalten.

	Ausf.: B vom 16.05.2007	
	A200861	
	Datum	Name
	Ersterst.	NHeinz
Geschr.	16.05.2007	NHeinz
Geprüft	16.05.2007	AHeinemann
Installationspaket Pneumatik		
Bestellnummer:		Sachnummer:
1-95813-P-00007-AAAA-Z03		101807



12.6 1-95813-B-00005-AAAA-Z03  
Tool identification



Pos.	Benennung	Identnr.	Zeichnungsnr.	Stueck	Werkstoff/Werkstoffnr.	Bemerkung
1	Haltewinkel	76973	4-95813-508-11-Z03	2.0000	ST37.2 1.0037K	
2	Trageschiene	76978	4-95813-509-11-Z03	2.0000	STAHL	
3	Bolzenhalter	76974	4-95813-510-11-Z03	1.0000	ST37.2 1.0037K	
4	Bolzenhalter	76977	4-95813-511-11-Z03	1.0000	9SMNPB28K 1.0718K	
5	Schaltbolzen	76975	4-95813-512-11-Z03	2.0000	ST37.2 1.0037K	
6	Schaltblech	77128	4-95813-516-11-Z03	1.0000	ST37.2 1.0037K	
7	Schaltblech	77130	4-95813-517-11-Z03	1.0000	ST37.2 1.0037K	
8	Rückstellfeder	66327	4-95806-506-05-Z03	2.0000	X12CRNI177 1.4310	
9	Schelle	76976	7-066-SM 112 A PP-IS	2.0000		
10	Näherungsinitiator	97945	7-119-IMG 12 BBDIX-35049	2.0000		
11	SCHEIBE	29019	DIN 125-A 8,4-A2	6.0000	X10CRNIS18 9 1.4305	

Die Zeichnung ist unser Eigentum. Jede Vervielfältigung, Verwertung oder Mitteilung an dritte Personen ist daher strafbar und wird gerichtlich verfolgt. (Urheberrechtsgesetz, Gesetz gegen unlauteren Wettbewerb, BGB). Alle Rechte für den Fall der Patenterteilung (§7 Abs. 1 PG) oder GM-Eintragung (§5 Abs. 4 GIMG) vorbehalten.

Ausf.: B vom 24.01.2007		WERKZEUGKENNUNG	
A200481			
	Datum	Name	
Erstest.	24.01.2007	GNeschen	
Geschr.	24.01.2007	GNeschen	
Geprüft.	24.01.2007	AHeinemann	
		Bestellnummer: 1-95813-B-00005-AAAA-Z03	
		Sachnummer: 76979	

Pos.	Benennung	Identnr.	Zeichnungsnr.	Stueck	Werkstoff/Werkstoffnr.	Bemerkung
12	SECHSKANTSCHRAUBE	19977	DIN 933-M 8 X 20-A2-70	4.0000	X10CRN18 9 1.4305	
13	SECHSKANTMUTTER	3768	DIN 934-M 8 X -A2-70	2.0000	X10CRN18 9 1.4305	
14	ZYLINDERSCHRAUBE	943	DIN 912-M 6X X 20-A2-70	4.0000	X10CRN18 9 1.4305	
15	ZYLINDERSCHRAUBE	3554	DIN 7984-M 6X 35-A2-70	2.0000	X10CRN18 9 1.4305	
16	ZYLINDERSCHRAUBE	1347	DIN 7984-M 5X 10-A2-70	4.0000	X10CRN18 9 1.4305	

Die Zeichnung ist unser Eigentum. Jede Vervielfältigung, Verwertung oder Mitteilung an dritte Personen ist daher strafbar und wird gerichtlich verfolgt. (Urheberrechtsgesetz, Gesetz gegen unlauteren Wettbewerb, BGB). Alle Rechte für den Fall der Patenterteilung (§7 Abs.1 PG) oder GM-Eintragung (§5 Abs.4 GMG) vorbehalten.

		Ausf.: <b>B</b> vom <b>24.01.2007</b>	
		<b>A200481</b>	
WERKZEUGKENNUNG			
Ersterst.	Datum	Name	
Geschr.	24.01.2007	GNeschen	
Geprüft.	24.01.2007	AHeinemann	
		Bestellnummer:	Sachnummer:
		1-95813-B-00005-AAAA-Z03	76979

## Drawings and parts lists

---

- 12.7 1-95813-B-00006-AAAA-Z03  
Security module (parking station)

K-D-GB

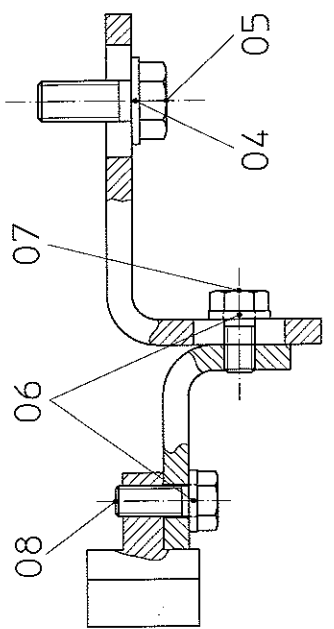
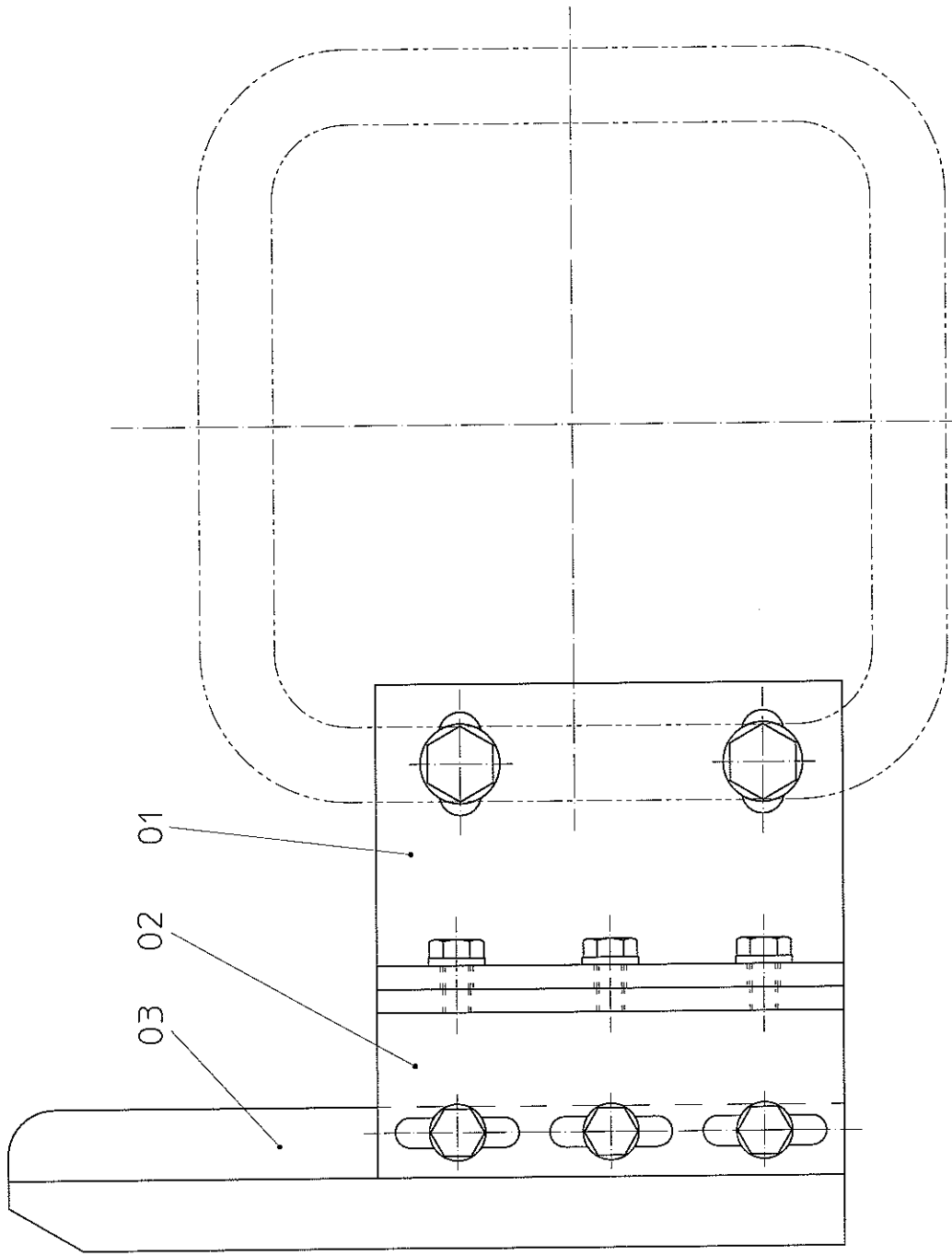

 Die Zeichnung ist unser Eigentum. Jede Vervielfältigung, Verwertung oder Mitteilung an Dritte Personen ist strafbar und wird gänzlich verweigert. Die Rechte für den Weiterverkauf, die Rechte für den Fall der Patenterteilung (Paragraph 7 Abs. 1 PatG oder DM-Eintragung Paragraph 5 Abs. 4 GEMA) vorbehalten.	
Ersatz für:	
Fertigungs- und Prüfvorschriften nach WALTHER - Werkstamm-Nr.: 12100.03	Ausführung: A
VOM: 28.12.2000	
Erstfertig: 28.12.00	
Gezeichnet: 25.01.01	
Geprüft: 30.01.01	
Name: VDH	
Name: VDH	
Name: RN	
1-95813-B-00006-....-Z03	
Maßstab: 1:1	
CAD-Zeichnung nicht manuell ändern!	
Sicherheitsmodul (Ablage)	
Security module (parking station)	

Pos.	Benennung	Identnr.	Zeichnungsnr.	Stueck	Werkstoff/Werkstoffnr.	Bemerkung
1	Befestigungswinkel	76981	4-95813-515-11-Z03	1.0000	SI37-2 1.0037K	
2	Haltewinkel	76980	4-95813-514-11-Z03	1.0000	SI37-2 1.0037K	
3	Schaltnocken	72311	4-95813-591-11-Z01	1.0000	SI37.2 1.0037K	
4	SCHEIBE	29019	DIN 125-A 8,4-A2	2.0000	X10CRNIS18 9 1.4305	
5	SECHSKANTSCHRAUBE	19977	DIN 933-M 8 X 20-A2-70	2.0000	X10CRNIS18 9 1.4305	
6	SCHEIBE	4398	DIN 125-A 6,4-A2	6.0000	X10CRNIS18 9 1.4305	
7	SECHSKANTSCHRAUBE	3429	DIN 933-M 6 X 12-A2-70	3.0000	X10CRNIS18 9 1.4305	
8	SECHSKANTSCHRAUBE	61952	DIN 933-M 6 X 16-A2-70	3.0000	X10CRNIS18 9 1.4305	

Die Zeichnung ist unser Eigentum. Jede Vervielfältigung, Verwertung oder Mitteilung an dritte Personen ist daher strafbar und wird gerichtlich verfolgt. (Urheberrechtsgesetz, Gesetz gegen unlauteren Wettbewerb, BGB). Alle Rechte für den Fall der Patenterteilung (§7 Abs.1 PG) oder GM-Eintragung (§5 Abs.4 GMG) vorbehalten.

		Ausf.: B vom 24.01.2007	
		A200481	
SICHERHEITSMODUL (ABLAGE)		Datum	Name
		Ersterst.	24.01.2007 G.Neschen
		Geschr.	24.01.2007 G.Neschen
Bestellnummer: 1-95813-B-00006-AAAA-Z03		Geprüft.	A.Heinemann
		Sachnummer: 76982	

12.8 1-95813-B-00016-AAAA-Z03  
Inscription



Pos.2 und 3 werden wahlweise an der Konsole  
oder am Grundkörper angebracht.  
Am Grundkörper z.B. bei  
Werkzeugaufblage 1-95813-00014-...-Z03

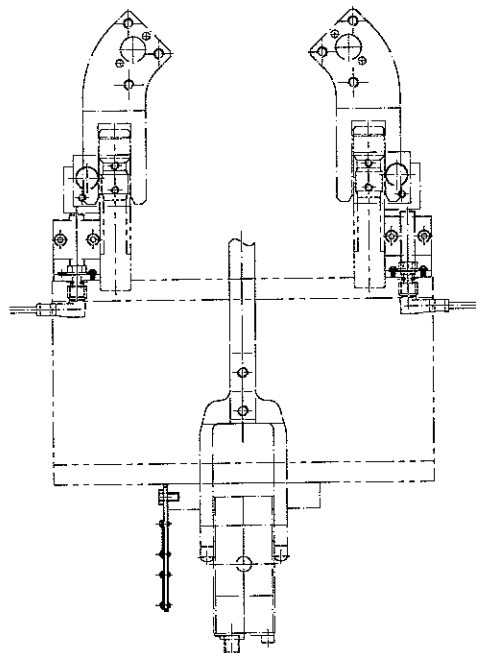
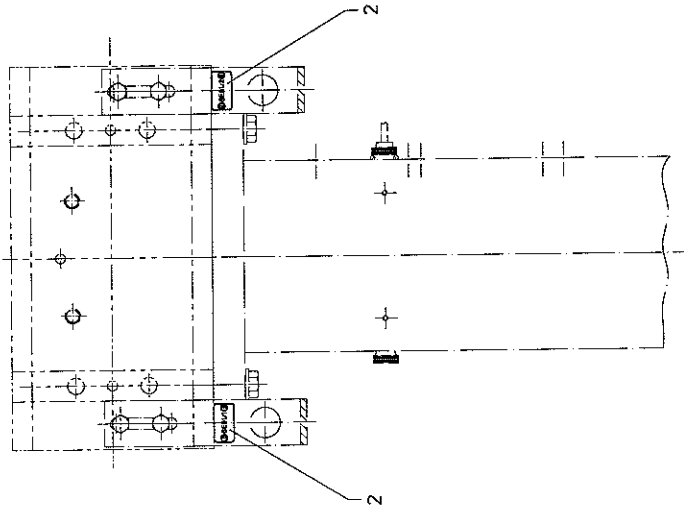
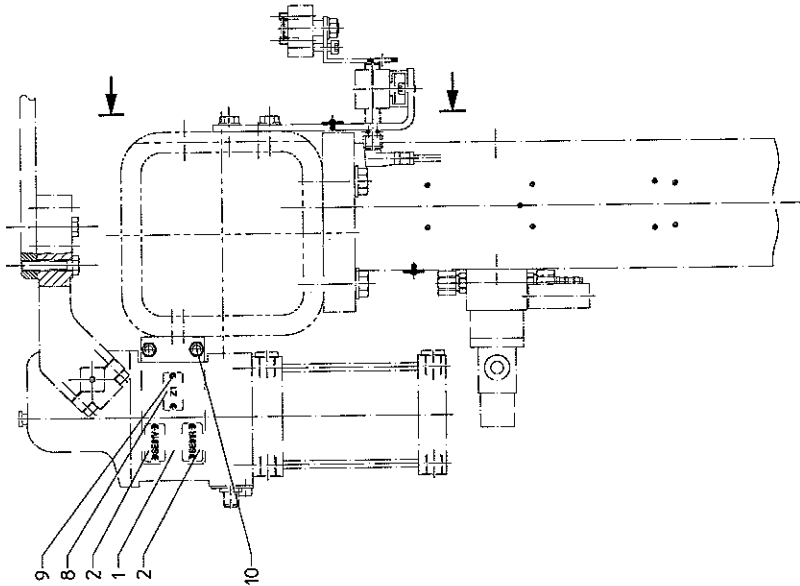
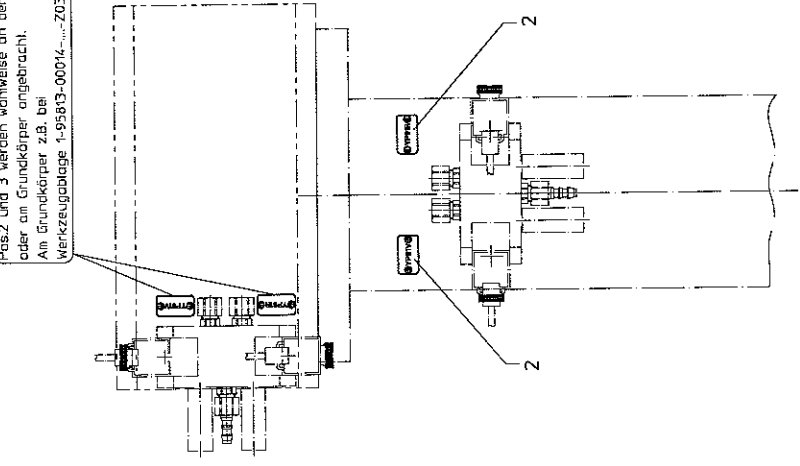

bei Montage beschriften / at mounting inscribe

		<b>1-95813-B-00016-...-Z03</b>	
Formel: 1,2 Ausführung: B Nach: WALTHER 2003/01/09 2003/01/09 2003/01/09 2003/01/24 KHK	Datum: 2003/01/09 JP 2003/01/09 JP 2003/01/09 KHK 2003/01/24 KHK	Name: 2003/01/09 JP 2003/01/09 JP 2003/01/09 KHK 2003/01/24 KHK	Beschriftung inscription
K D-GB PT 6308			

Pos.	Benennung	Identnr.	Zeichnungsnr.	Stueck	Werkstoff/Werkstoffnr.	Bemerkung
01	Beschriftungsblech	83822	4-95813-520-11-Z03	1.0000	ST37.2 1.0037K	
02	Kennzeichnungsschild	47947	7-137-7723-ELOX	14.0000	AL	
08	Kennzeichnungsschild	83781	7-137-7723-Z1	1.0000	AL	
09	KERBNAGEL	83823	DIN 1476 3 X 6	14.0000	STAHL	
10	SECHSKANTSCHRAUBE	3429	DIN 933-M 6 X 12-A2-70	2.0000	X10CRNiS18 9 1.4305	

Die Zeichnung ist unser Eigentum. Jede Vervielfältigung, Verwertung oder Mitteilung an dritte Personen ist daher strafbar und wird gerichtlich verfolgt. (Urheberrechtsgesetz, Gesetz gegen unlauteren Wettbewerb, BGB). Alle Rechte für den Fall der Patenterteilung (§7 Abs.1 PG) oder GM-Eintragung (§5 Abs.4 GMG) vorbehalten.

Ausf.: B vom 24.01.2007		BESCHRIFTUNG	
A200481			
	Datum	Name	
Ersterst.	24.01.2007	GNeschen	
Geschr.	24.01.2007	GNeschen	Sachnummer: 42517
Geprüft.	24.01.2007	AHeinemann	Bestellnummer: 1-95813-B-00016-AAAA-Z03



13 Index

*A*

according .....	5
Acquired knowledge.....	4
Air pressure connection.....	8, 9
Aktor sensor box .....	8
Alterations .....	4
anchored .....	7, 9
Aperture angle of protection cover.....	8
applications.....	7

*C*

center of gravity .....	11
check.....	12, 13
commissioning .....	12
Commissioning.....	4
contaminations .....	8
coupling.....	4, 5
Customer care.....	2

*D*

damage .....	5
Damage.....	4
Damage compensation .....	4
Danger references.....	5
dangerous spreading .....	5
disconnection.....	7
dismounting.....	5
Drill picture .....	8

*E*

Equipment .....	4
Experience.....	4

*F*

Faults .....	4
first use .....	5
functional.....	5
functional test .....	5
Functionality.....	2

*G*

General safety instructions .....	12, 13
guarantee .....	5

*H*

Height of parking station.....	8
--------------------------------	---

*I*

Improvement .....	4
individual particles .....	5
Inhaltsverzeichnis.....	3
Inspection .....	2
installation package electro.....	7
installation package pneumatic .....	7
Interbus module.....	8, 10

*L*

level adjustment .....	7, 8, 9
Liability.....	4

*M*

Main dimensions .....	7
maintenance .....	5
Maintenance .....	2, 4, 5
Manual .....	4
mass center.....	11
Maximum load .....	7
medium.....	5
mounting .....	5

*O*

observed .....	5
operating instruction .....	5
Operation.....	2
operator .....	5
Operators.....	2
orderly .....	5
orderly operation .....	5
original .....	4

*P*

Performance capability.....	2
plan protective measures .....	5
plastic plate .....	8
pressurized .....	5
Property .....	4
protection cover.....	7, 11, 12, 13
protection cover (hinged cover) .....	7

*Q*

questions.....	4
----------------	---

*R*

readable form. ....	5
---------------------	---

realization .....	5	Support distance .....	7
receptacles .....	11	Systems .....	2
Regulations .....	4	<i>T</i>	
relevant industrial safety regulations.....	5	Technical equipment.....	2
Reliability .....	2	Tool clearance .....	7
removed .....	5	tool geometry .....	7
repair.....	5	tool identification .....	7
result .....	5	tool parking station.....	7, 11, 13
<i>S</i>		tool strong shock .....	11
Safety.....	2	Tools .....	2
safety devices .....	5	torque .....	8
safety instructions.....	5	Translation errors .....	4
safety module .....	7	<i>U</i>	
Scope of delivery.....	4	usage.....	5
screwed.....	12	Use .....	2
screw-type connections .....	5	<i>V</i>	
Service.....	2	Version .....	4
Sicherheitshinweise .....	5	<i>W</i>	
Special designs .....	4	working area.....	11
Specialists.....	2	wrong product selection .....	5
specification .....	5		
stand .....	7, 11, 12, 13		
Status of development .....	4		
support.....	7, 11, 13		