

3,2 (✓)

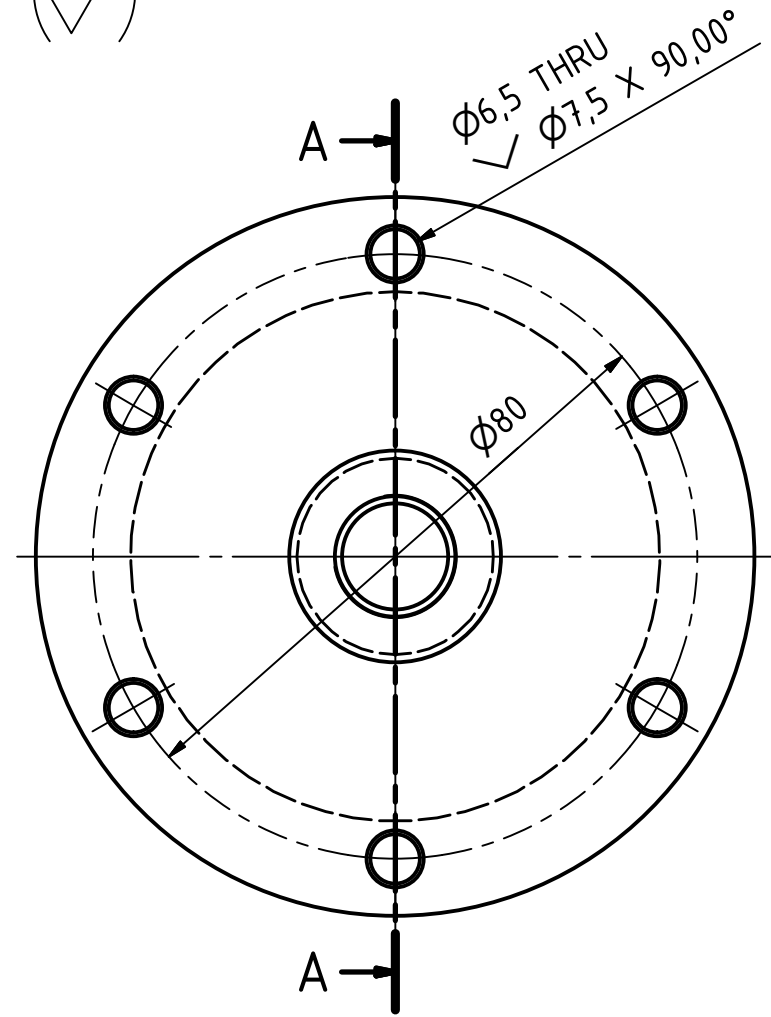

A-A (1 : 1)

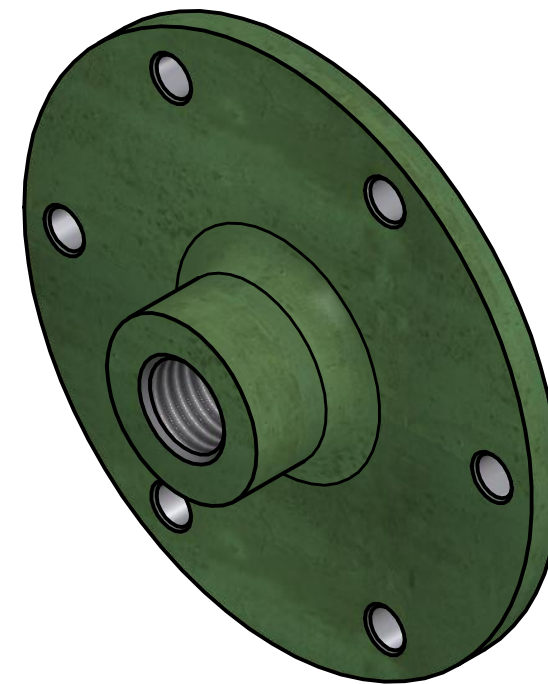
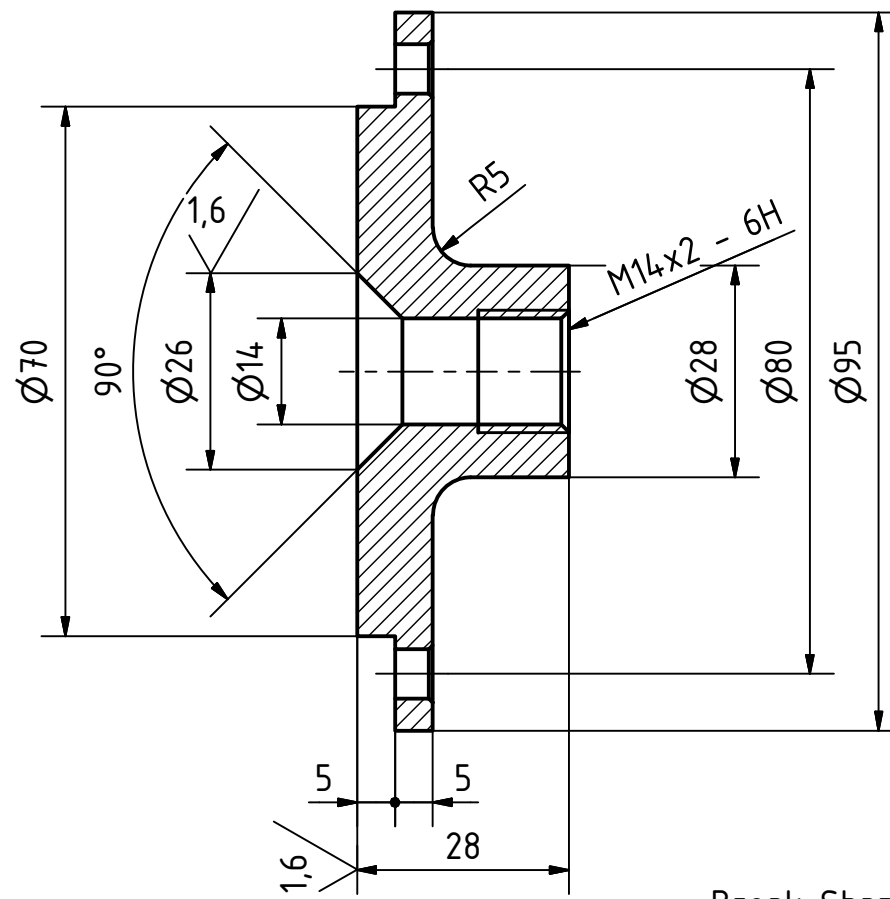

Break Sharp Edges: 0,1 mm

Revision	Date	Description	Engineered by:		Name:	Date:	Scale: 1:1	
			Designer:	Galba, J.	1/12/2010	Sheet Size: A3		
			Approved:	Galba, J.	1/12/2010			
Project: Miniature Model Steam Engine							Material: Aluminum-6061	
							Total Mass: 0.162 kg	

Title:		Horizontal Beam Engine with Centrifugal Pump	
		Centrifugal Pump Cover	

Corresponding symbols		▽	▼	▽▽	▼▼	▽▽▽	▼▼▼											
Roughness Classes (NBN 88-02) (ISO 1302)		N11	N10	N9	N8	N7	N6	N5	N4									
Roughness Value "Ra" in µm (NBN 88-02) (ISO 1302)		25	12,5	6,3	3,2	1,6	0,8	0,4	0,2									
Allowable deviations for dimensions without tolerance indication (machined surfaces)																		
		For measurements (deviations in mm)							Fillet and chamfers			Angles (in ° and ')						
Accuracy class (ISO 2768.1)	Dimensions in mm								Dimensions in mm					Length of the shortest leg				
	0,5 to 3	>3 to 6	>6 to 30	>30 to 120	>120 to 400	>400 to 1000	>1000 to 2000	>2000 to 4000	0,5 to 3	>3 to 6	>6 to 30	>30 to 120	>120 to 400	to 10	>10 to 50	>50 to 120	>120 to 400	above 400
f Fine	±0,05	±0,05	±0,1	±0,15	±0,2	±0,3	±0,5	±0,8	±0,2	±0,5	±1	±2	±4	±1°	±30'	±20'	±10'	±5'
m Medium	±0,1	±0,1	±0,2	±0,3	±0,5	±0,8	±1,2	±2										
c Rough	±0,2	±0,3	±0,5	±0,8	±1,2	±2	±3	±4	±0,4	±1	±2	±4	±8	±1°30'	±1°	±30'	±15'	±10'
v Very Rough	-	±0,5	±1	±1,5	±2,5	±4	±6	±8						±3°	±2°	±1°	±30'	±20'

	Drawing number:		Sheet: 0001
	Design State:	Released	Drawing made with Autodesk Inventor Revisions only permitted by CAD

This document is for educational purposes only and property of Inventor Wizard. It shall not without our permission be altered, copied, used for manufacturing or communicated to any other person or company.