

1,6 (M)

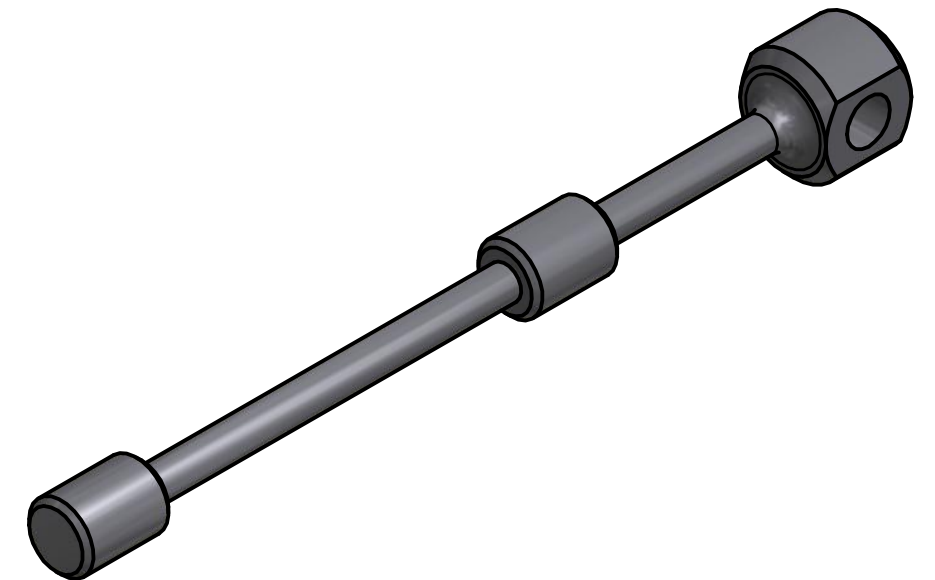
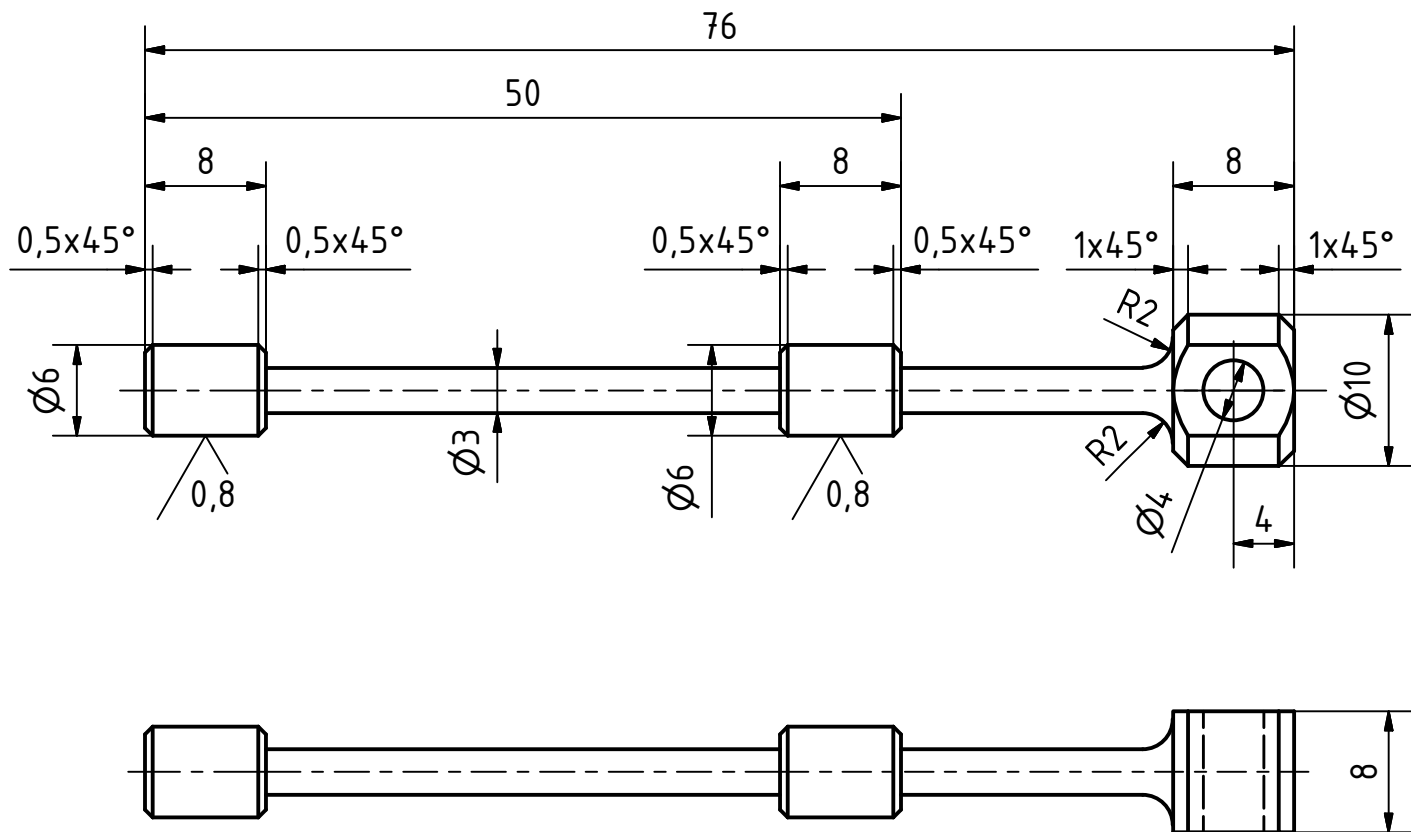

Break Sharp Edges: 0,1 mm

Revision	Date	Description				
Engineered by:			Name:	Date:	Scale: 2:1	
			Designer: Galba, J.	1/12/2010	SheetSize: A3	
			Approved: Galba, J.	1/12/2010		
Project: Miniature Model Steam Engine					Material: Stainless Steel	
					Total Mass: 0.010 kg	

Title: Horizontal Beam Engine with Centrifugal Pump Valve	
--	--

Corresponding symbols		▽	▼	▽▽	▼▼	▽▽▽	▼▼▼											
Roughness Classes (NBN 88-02) (ISO 1302)		N11	N10	N9	N8	N7	N6	N5	N4									
Roughness Value "Ra" in µm (NBN 88-02) (ISO 1302)		25	12,5	6,3	3,2	1,6	0,8	0,4	0,2									
Allowable deviations for dimensions without tolerance indication (machined surfaces)																		
		For measurements (deviations in mm)							Filletes and chamfers			Angles (in ° and ')						
Accuracyclass (ISO 2768.1)	Dimensions in mm								Dimensions in mm					Length of the shortest leg				
	0,5 to 3	>3 to 6	>6 to 30	>30 to 120	>120 to 400	>400 to 1000	>1000 to 2000	>2000 to 4000	0,5 to 3	>3 to 6	>6 to 30	>30 to 120	>120 to 400	to 10	>10 to 50	>50 to 120	>120 to 400	above 400
f Fine	±0,05	±0,05	±0,1	±0,15	±0,2	±0,3	±0,5	±0,8	±0,2	±0,5	±1	±2	±4	±1°	±30'	±20'	±10'	±5'
m Medium	±0,1	±0,1	±0,2	±0,3	±0,5	±0,8	±1,2	±2										
c Rough	±0,2	±0,3	±0,5	±0,8	±1,2	±2	±3	±4						±1°30'	±1°	±30'	±15'	±10'
v Very Rough	-	±0,5	±1	±1,5	±2,5	±4	±6	±8	±0,4	±1	±2	±4	±8	±3°	±2°	±1°	±30'	±20'

	Drawingnumber:	Sheet: 0001
	Design State: Released	Drawing made with autodesk Inventor Revisions only permitted by CAD

This document is for educational purposes only and property of Inventor Wizard. It shall not without our permission be altered, copied, used for manufacturing or communicated to any other person or company.