

# Yilida Air Conditioning Ventilation Technical Manual

SYBS Series Centrifugal Ventilators  
SYBS 系列离心式空调风机

**Yilida**<sup>®</sup>

The Smart Air

## 概述

SYBS 系列单进风离心式空调风机流量 300m<sup>3</sup>/h~4000m<sup>3</sup>/h, 采用外转子电机直联传动, 具有效率高、噪声低、结构紧凑等特点, 是变风量空调器、管道式空调机组、VAV 系统及其他暖通空调、净化设备理想的配套产品。

## Summary

The volume flow ranges of SYBS series single inlet centrifugal air-conditioning fans from 300m<sup>3</sup>/h to 4200m<sup>3</sup>/h. SYBS series fans are characterized by compact construction, high efficiency and low noise. They are the ideal subsidiary equipment for various cabinets central air-conditioning units and heating, air-conditioning, cleansing and ventilating equipments.

## 命名方式

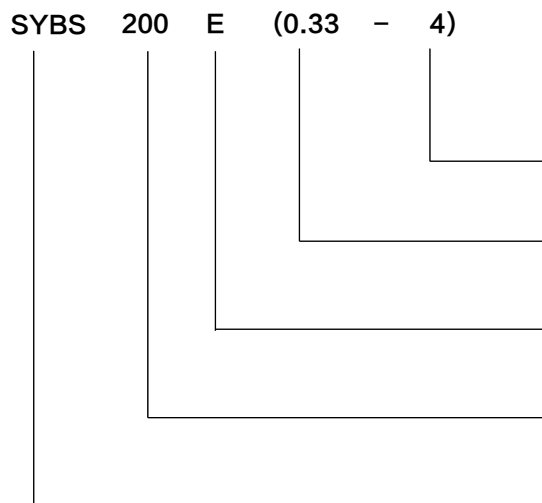

## Nomenclature

- 电机极数  
Motor polar number
- 电机功率(kW)  
Motor power (kW)
- 电源(E- 单相, D- 三相)  
Power supply (E-single phase, D-three phase)
- 叶轮名义直径(mm)  
Nominal diameter of Wheel (mm)
- 前向多翼型离心风机系列代号  
Fan series with multi-vane forward curved blades

## 产品型式

### 1. 旋向

SYBS 系列风机可按图 1 分为左旋(LG)和右旋(RG)两种旋转方式, 从进风一端正视, 叶轮顺时针旋转的称为右旋风机, 逆时针旋转的称为左旋风机。

## Product Features

### 1. Rotation direction

SYBS series fan can be divided into two directions of rotations, left-hand rotation (LG) and right-hand (RD); Viewing from the end hub the Wheel rotates clockwise, it is called right hand fan; if the Wheel rotations' anti-clockwise, it is called left hand fan.

## 2. 出风口方向

SYBS 系列风机可按图 2 所示制成 0°、90°、180°、270° 四种出风方向。



图 1( Fig 1 )

## 2. Discharge Direction

According to Fig2, SYBS Series fans can be made in four air-outlet directions: 0°, 90°, 180°, and 270°.

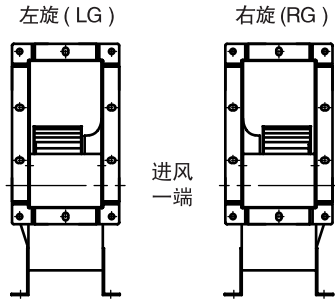

图 2( Fig 2 )

## 产品结构

SYBS 系列风机主要由机壳、叶轮、支板、电机、四部分组成。

### 1. 机壳

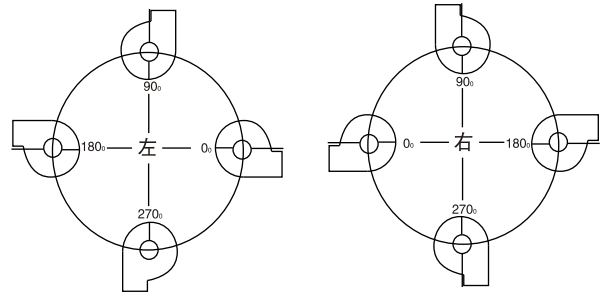
机壳采用热镀锌钢板制造，侧板具有符合空气动力的外形，进风口整体拉伸成型，蜗板采用点焊方式与侧板连成一体。在侧板上预设一系列的铆螺母孔，以便按照用户要求的出风口方向进行安装。

### 2. 叶轮

前向多翼叶轮采用优质热镀锌板钢板制成，叶片设计成符合空气动力学的特定形状，使得效率最高，噪声最低。叶片用铆爪固定在中盘及端圈上，在最大功率连续运转时，叶轮将具备足够的刚度。所有叶轮进行静平衡和动平衡测试，内控精度达到 G2.5 级 (ANSI/AMCA 204-05)。

### 3. 支板( 框架 )

支板采用优质镀锌板制成，独特加强工艺保证足够的强度，支板安装角度可以根据用户的不同需求进行调整。

### 4. 电机

SYB 系列风机配用外转子低噪声单相、三相电动机，该电机调速范围广，可采用调压及变频等手段进行无级调速，以适应系统负荷多变的要求。

## Construction of Product

SYBS series fans consist of housing, Wheel, baseplate and motor.

### 1. Housing

The housing is made of hot galvanized steel sheet. The side plates include inlets cones that are designed with the best aerodynamics for inlet condition. The scroll is fixed to the side plates by spot welding. On the side of the scroll, there is a series of holes drilled in advance for riveting nuts to carry out installation according to air outlet direction needed by the customer.

### 2. Wheel

Forward curved Wheel is constructed of high-grade hot galvanized steel sheet with the advanced aerodynamics profile to achieve the highest efficiency and the lowest noise level. The Wheel is fixed on the center plate and on the end ring with riveting grip pres. The Wheel is constructed with maximum strength that endures the continuous operation with maximum power. All Wheels are balanced to the ANSI/AMCA 204-05 Notional Standard. Yilida's internal standard is G2.5 or higher for wheel balancing.

### 3. Frame

SYBS Series fan baseplate is made of high quality hot galvanizing steel sheet, and the unique process of strengthening ensures the sufficient strength. The direction of baseplate installation can be carried out according to the different requirements of customers,

### 4. Motor

The motor used in SYBS series fans are equipped with low noise single-phase, or three-phase, The motor rotation speed can be changed by using pressure regulator and frequency converter.

## 说明

- 1). 风机配用电机功率是指在特定工况下，内功率加上电机容量安全系数而言，并非出风口全开时所需的功率，因此为防止电机因超功率运转而烧毁，严禁风机未加任何外界阻力进行空运转。
- 2). 样本中的风机性能是选用电机额定转速测试的结果，我们亦可通过改变电机的转速达到用户实际的需求。
- 3). 风机在运输、装卸过程中应小心轻放，严禁撞击挤压，严禁堆放于潮湿或有腐蚀性的场合。
- 4). 风机安装前应用手拨动叶轮，检查是否有过紧或碰撞现象，确认没有这些现象时方可进行试运转。
- 5). 风管与风机进风口、出风口之间连接时应尽量采用软连接，接头不得拉得过紧。
- 6). 风机安装后应检查机壳和其他壳体内部，不应遗留的工具和杂物。
- 7). 风机正式运转前，需检查叶轮的转向是否符合侧板上的转向标记。
- 8). 订货时需注明风机型号、配用电机型号、风机的风量、风压等参数。

## Instructions

- 1) The rated motor power as calculated herein might not be sufficient to drive the fan with an unrestricted discharge flow. Operating the fan with an unrestricted discharge outlet will result in flow rate that exceeds the specified fan capabilities. Such operation will quickly burn the motor and damage the fan. Great care must be taken in operating the fan to make sure that the maximum rated flows, as provided on the performance charts in this catalog, are not exceeded.
- 2) The fan performance in the catalog is tested under the motor rated speed, we can meet the actual requirement of the user by changing the motor speed.
- 3) Special care should be taken during transportation, load and unload. The fan is limited for use in areas where air substances are non-corrosive, non-toxics and non-erosive.
- 4) Following the installation, the Wheel should be turned by hand or with the use of a wrench to make sure that it turns freely without colliding with other parts of the fan. Once all this is done, the fan can be commissioned normally.
- 5) A flexible connector should be used between the fan out let flange and its mating ductwork. The flex connector should not be over-stretched.
- 6) The inside of the scroll and casing need to be checked to make sure that there are no foreign objects inside the housing, such as tools or loose parts.
- 7) The rotational directions of the motor and Wheel should be checked to ensure that they are in compliance with the specification and purchase orders.
- 8) During ordering it is necessary to state the type of fan, motor type, air flow, air pressure and other parameters.

技术参数

Technical Data

SYBS 200E

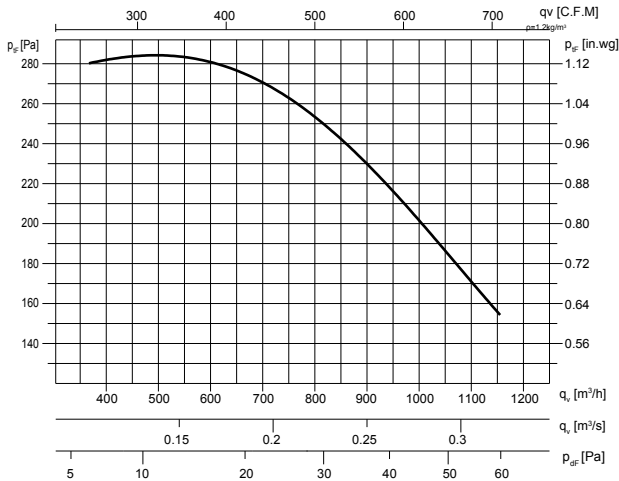

SYBS 200D

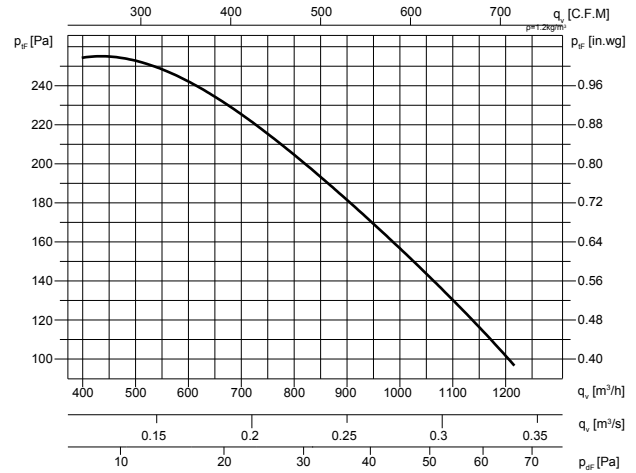

Type: SYBS 200E-4	m: 11 kg	$P_N$ : 0.33kW-4P
	U: 230 v	N: 1280 r/min
	$I_N$ : 1.5 A	IP: IP54

Type: SYBS 200D-4	m: 11 kg	$P_N$ : 0.33kW-4P
	U: 380 V	N: 1270r/min
	$I_N$ : 0.63 A	IP: IP54

外形及安装尺寸

Overall Size

注：外形尺寸的单位为 mm。

Note: the overall size unit is mm.

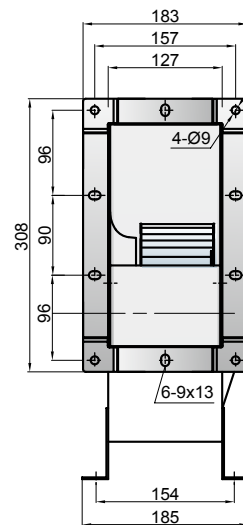
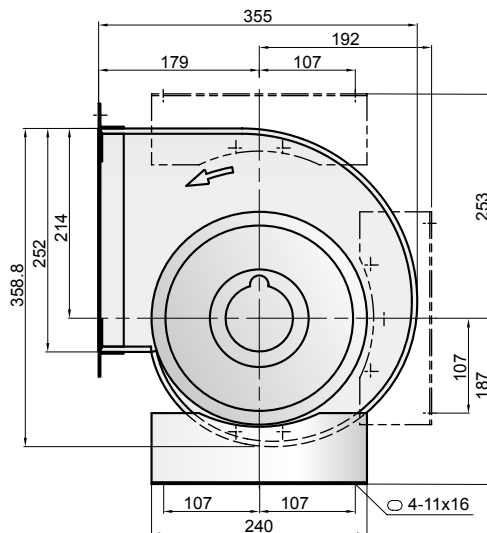

技术参数

Technical Data

SYBS 225E

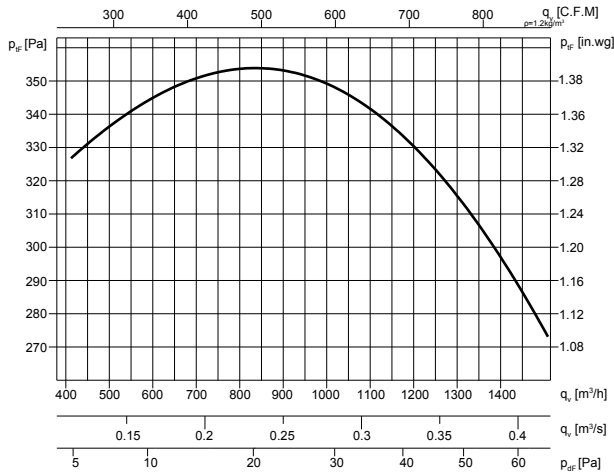

SYBS 225D

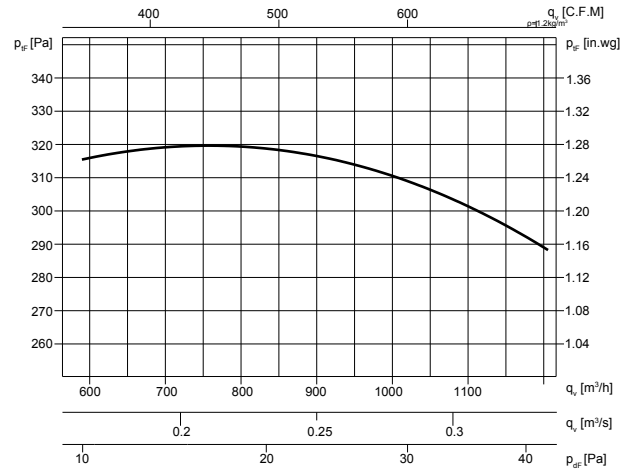

Type:	m: 14 kg	$P_N$ : 0.48kW-4P
SYBS 225E-4	U: 230 v	N: 1330 r/min
	$I_N$ : 2.2 A	IP: IP54

Type:	m: 14 kg	$P_N$ : 0.36kW-4P
SYBS 225D-4	U: 380 v	N: 1330r/min
	$I_N$ : 0.68 A	IP: IP54

外形及安装尺寸

Overall Size

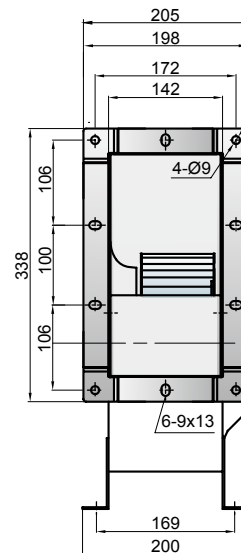
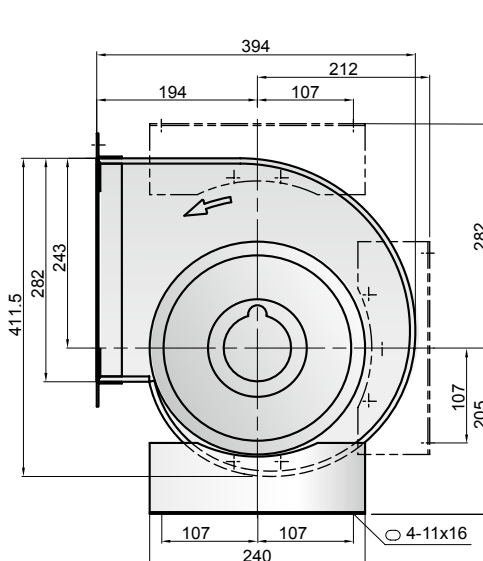

技术参数

Technical Data

SYBS 250E

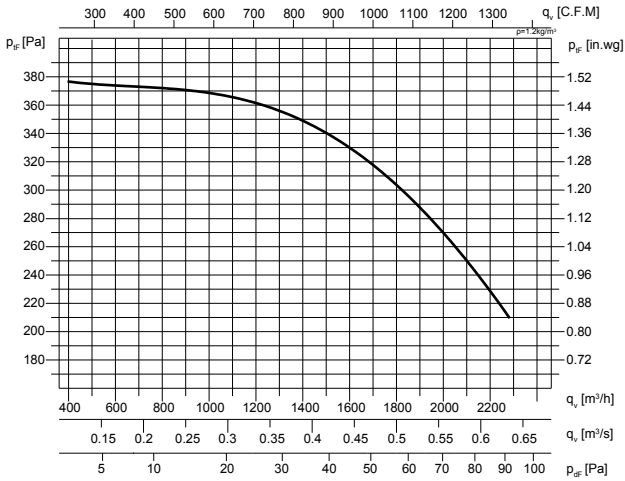

SYBS 250E

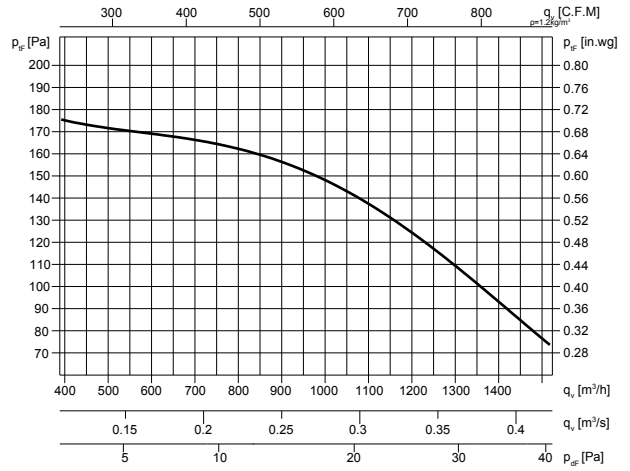

Type:	m: 17 kg	PN: 0.81kW-4P
SYBS 250E-4	U: 230 v	N: 1330 r/min
	IN: 3.65 A	IP: IP54

Type:	m: 17 kg	PN: 0.32kW-6P
SYBS 250E-6	U: 230 v	N: 890r/min
	IN: 1.6 A	IP: IP54

外形及安装尺寸

Overall Size

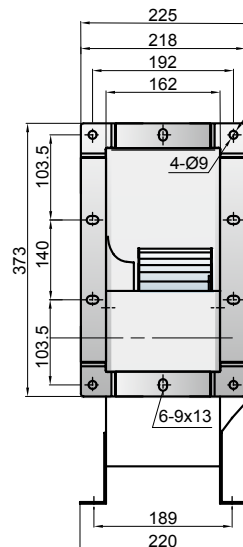
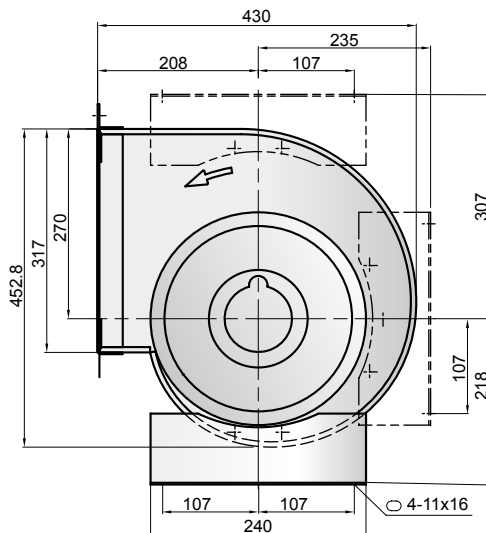

技术参数

Technical Data

SYBS 250D

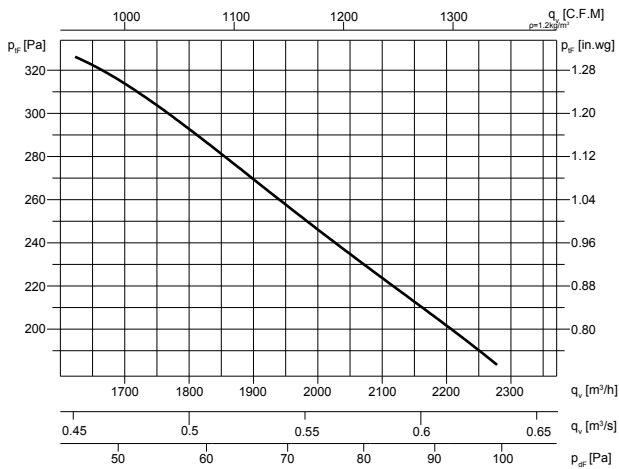

Type:	m: 17 kg	PN: 0.85kW-4P
SYBS 250D-4	U: 380 v	N: 1370 r/min
	IN: 1.7 A	IP: IP54

外形及安装尺寸

Overall Size

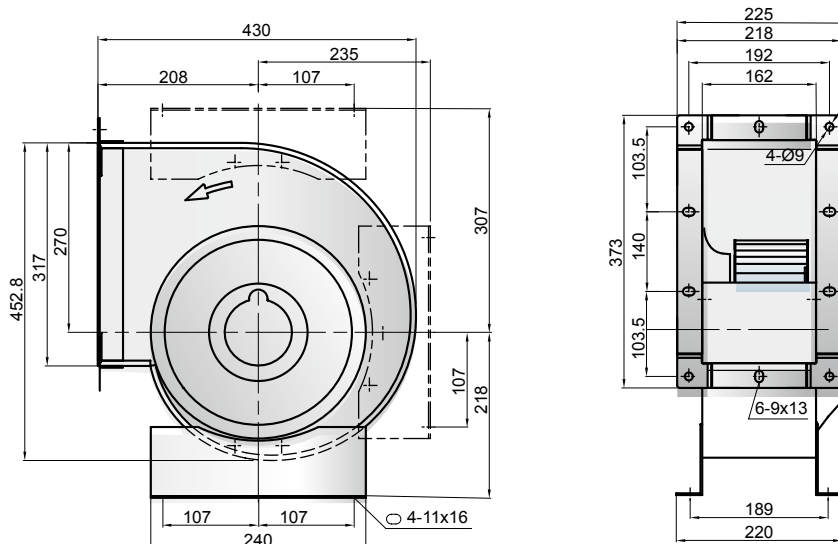



技术参数

Technical Data

SYBS 280E

SYBS 280E

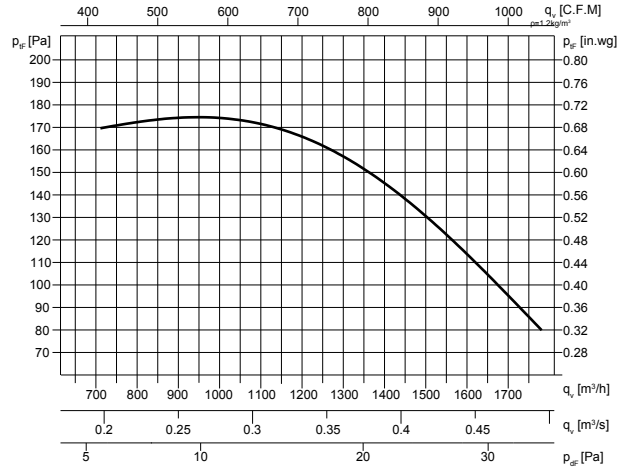
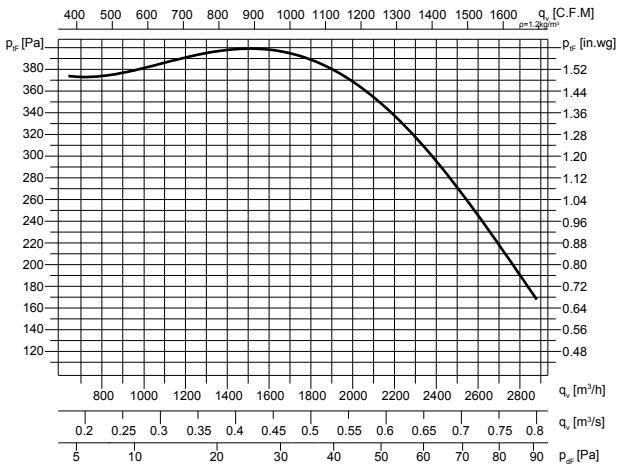

Type:	m: 26 kg	$P_N$ : 1.25kW-4P
SYBS 280E-4	U: 230 v	N: 1380 r/min
	$I_N$ : 5.6 A	IP: IP54

Type:	m: 26 kg	$P_N$ : 0.33kW-6P
SYBS 280E-6	U: 230 v	N: 930r/min
	$I_N$ : 1.7 A	IP: IP54

外形及安装尺寸

Overall Size

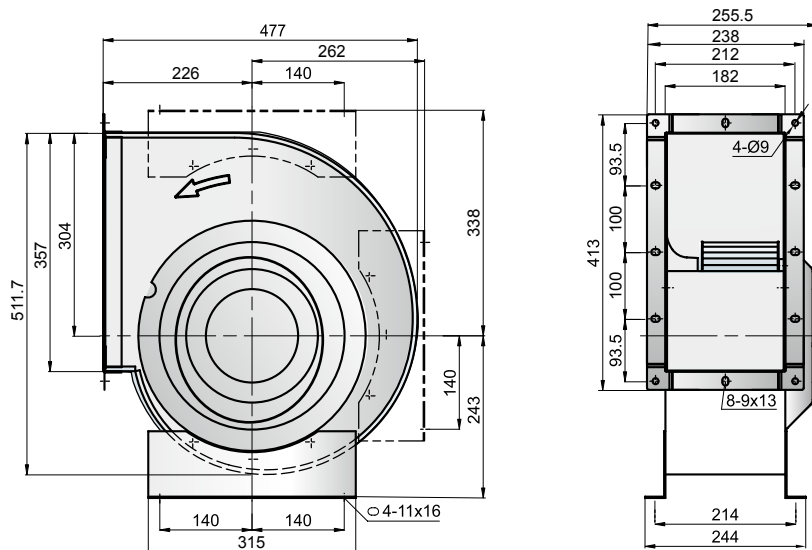

技术参数

Technical Data

SYBS 280D

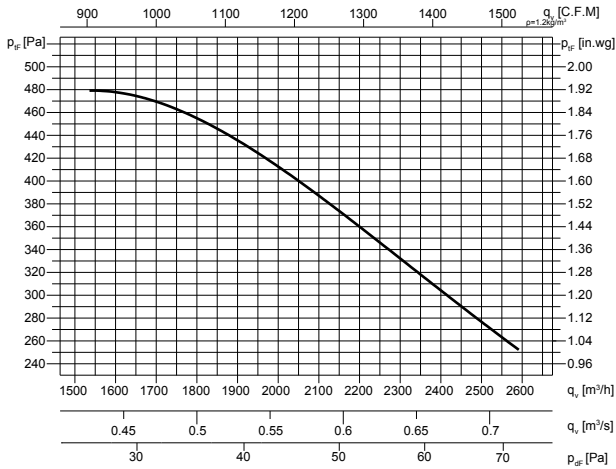

Type:	m: 26 kg	PN: 1kW-4P
SYBS 280D-4	U: 380 v	N: 1280 r/min
	IN: 1.7 A	IP: IP54

外形及安装尺寸

Overall Size

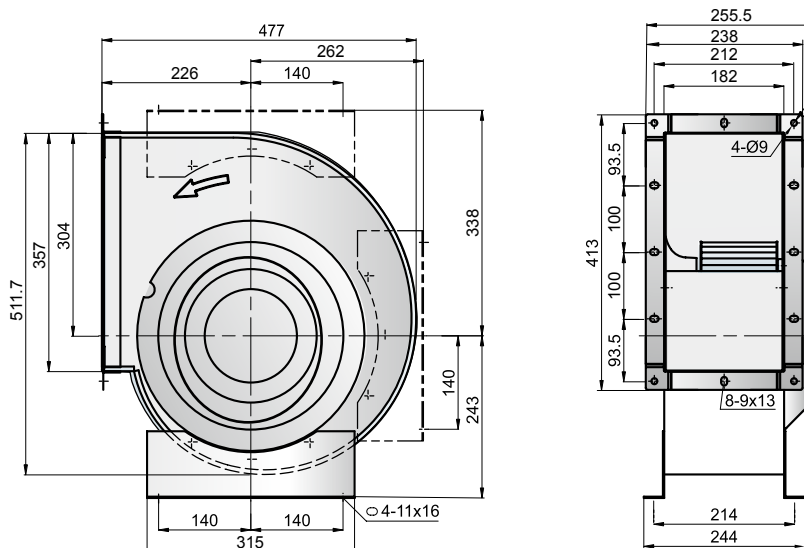

技术参数

Technical Data

SYBS 315E

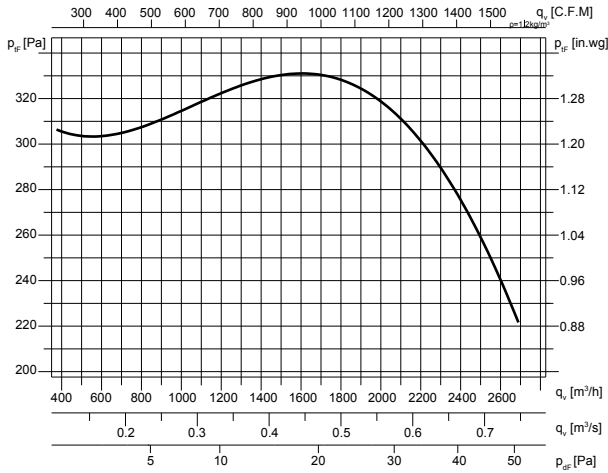

SYBS 315D

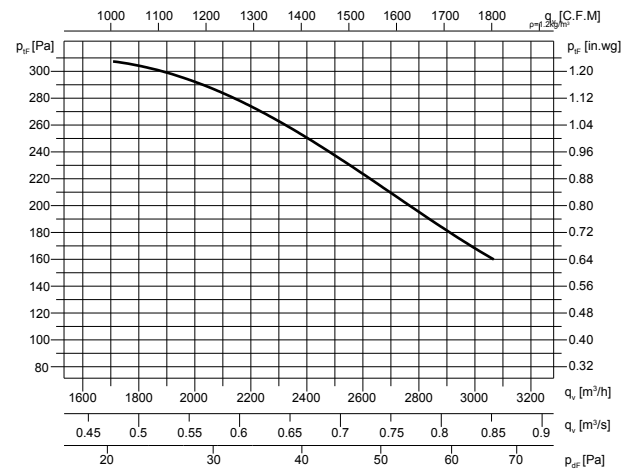

Type: SYBS 315E-6	m: 29.5 kg	$P_N$ : 0.75kW-6P
	U: 230 v	N: 870 r/min
	$I_N$ : 3.6 A	IP: IP54

Type: SYBS 315D-6	m: 29.5 kg	$P_N$ : 0.78W-6P
	U: 380 v	N: 840r/min
	$I_N$ : 1.5 A	IP: IP54

外形及安装尺寸

Overall Size

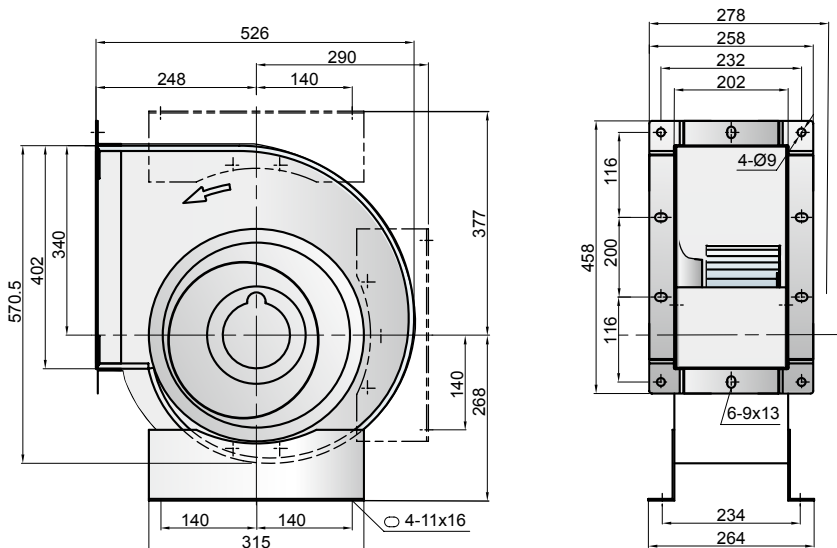

技术参数

Technical Data

SYBS 355D

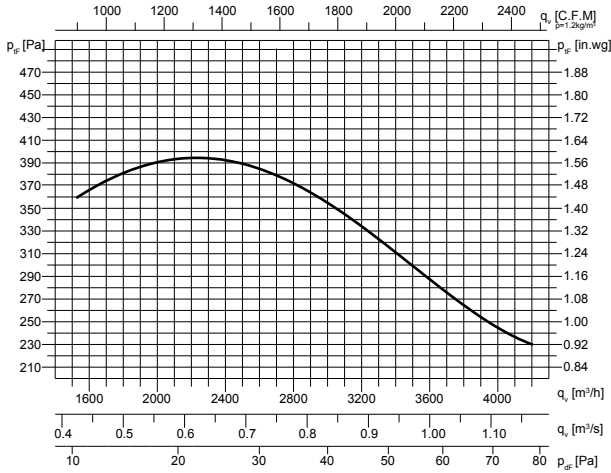

SYBS 355D

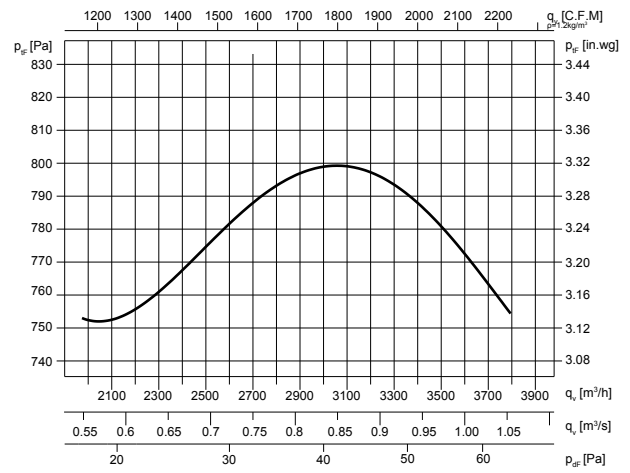

Type:	m: 37 kg	$P_N$ : 1.15W-6P
SYBS 355D-6	U: 380 v	N: 810 r/min
	$I_N$ : 2.2 A	IP: IP54

Type:	m: 38 kg	$P_N$ : 2kW-4P
SYBS 355D-4	U: 380 v	N: 1360r/min
	$I_N$ : 3.8 A	IP: IP54

外形及安装尺寸

Overall Size

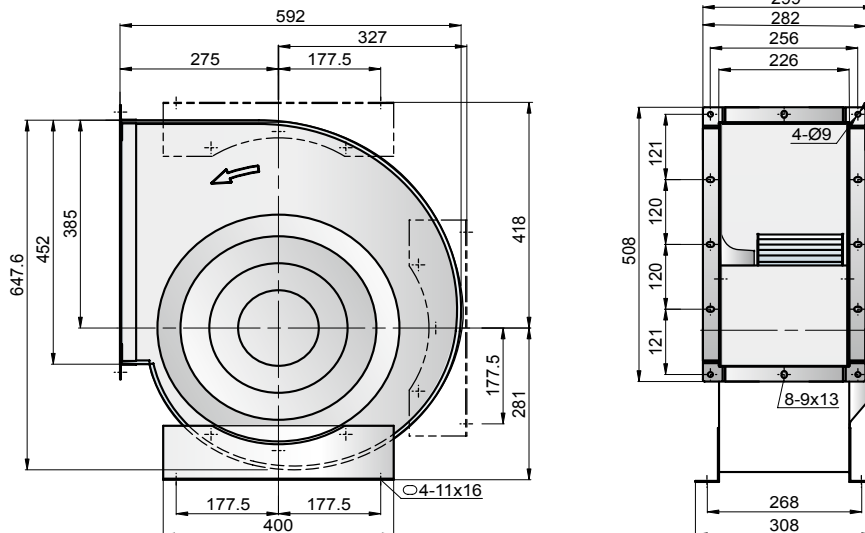

Zhejiang Yilida Ventilator Co., Ltd.  
浙江亿利达风机股份有限公司

Yilida Road, Hengjie, Luqiao District, Taizhou City, Zhejiang, China P.C: 318056  
中国浙江台州市路桥区横街亿利达路

Tel : +86 576 82656000 +86 576 82652200  
Fax : +86 576 82655758  
E-mail : info@yilida.com

Hot Line ( 全球服务热线 ) : 400 1135 666 International Trade ( 国际贸易 ) : +86 576 82622666 [www.yilida.com](http://www.yilida.com)

Version Number: A201303 The rights of final interpretation of this brochure belongs to Yilida.  
© 2013 All Rights Reserved by Yilida

版本号 : A201303 该手册最终解释权归亿利达股份公司所有  
© 2013 亿利达拥有版权并保留所有权利

本样本中所述的风机特性，如尺寸、性能参数等，本公司保留更改的权利，恕不另行通知；如有不明之处，请来电询问。  
This fan features described in the sample, such as size, performance parameters, the Company reserves the right to change without notice; if unknown place, please call us.