

Industrial aluminum profiles

Integrated services expert

工业铝型材集成服务专家

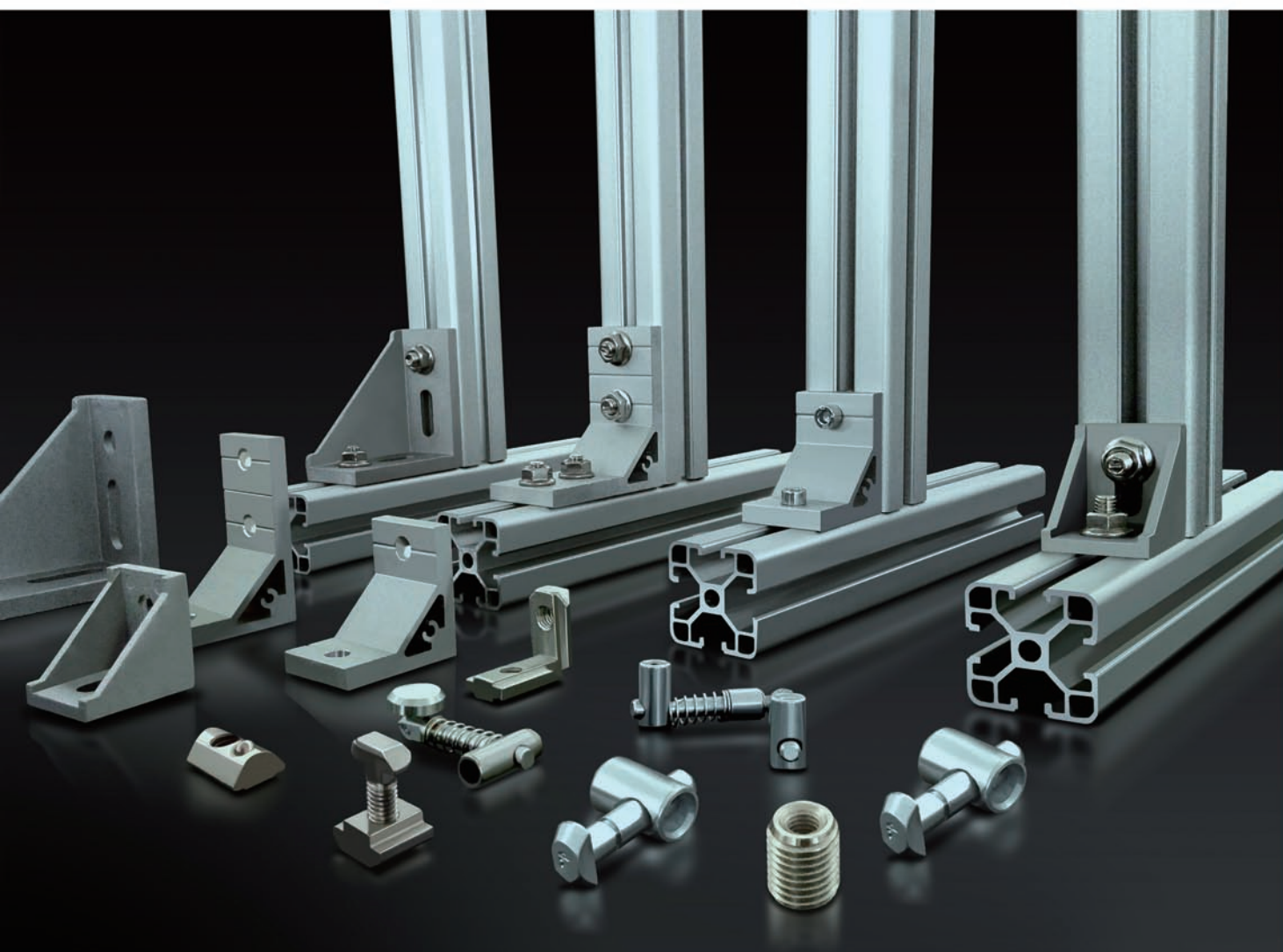

Contact US
联系艾普斯：
022-87887696

天津艾普斯工业铝型材股份有限公司
Tianjin APAS aluminum industry Limited by Share Ltd



2

Wire rod system 铝型材线棒系统

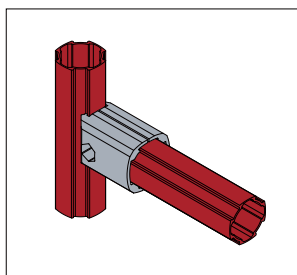

精益管线棒
Lean management
page: 101-102

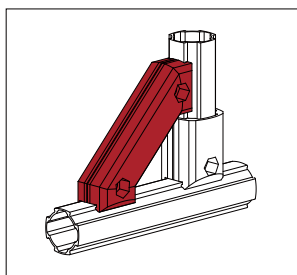

配件连接件
Connector
page: 103-109

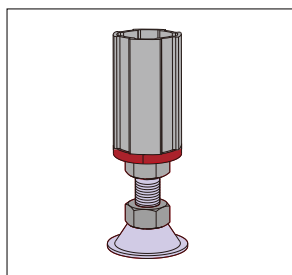

支撑件配件
Supporting member
page: 110

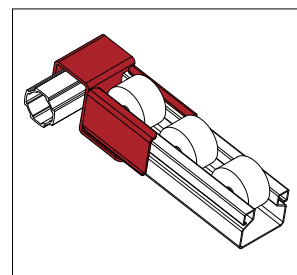

流利条滑道
Fluent article
page: 112-114

Purpose

主要用途：

Good shelves

①：仓储货架

Material car

②：物料车

Transmission line

③：物料输送线

Workbench

④：工作台

线棒系统应用：

铝型材线棒系统主要应用于承载需求较低的框架结构。

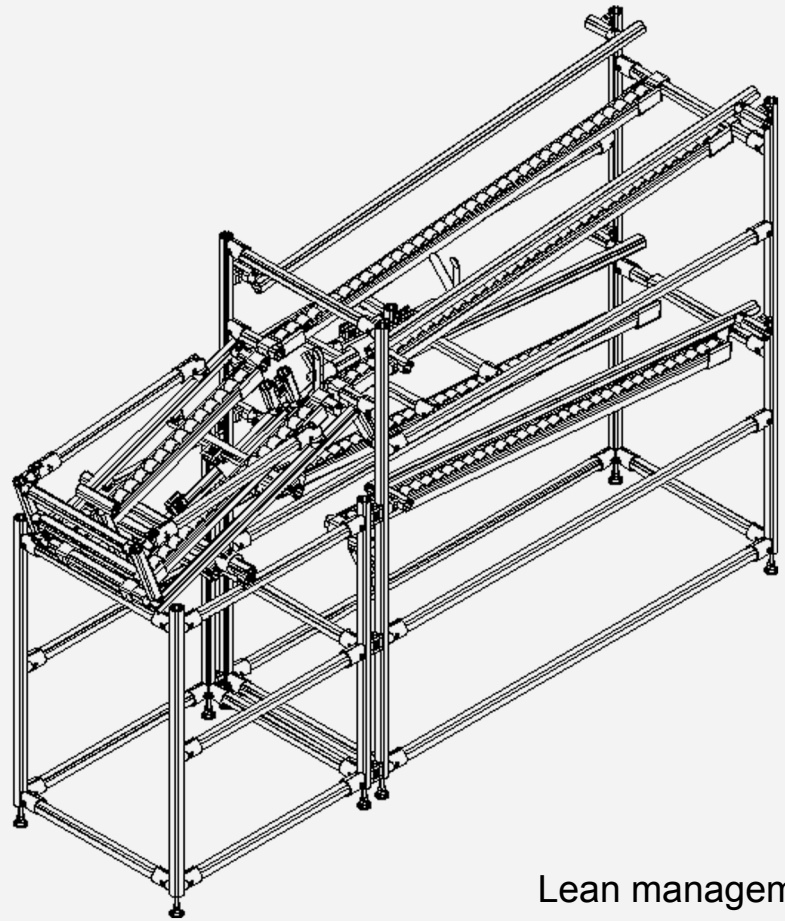

Lean management

精益管组装系统



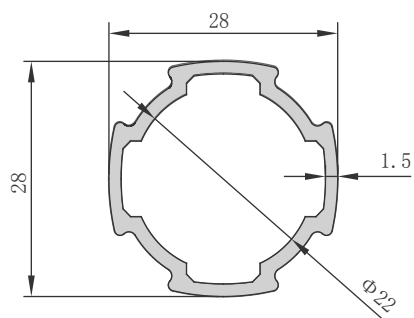

| 型号 | 材质 | 重量kg/m | 订货编号 |
|------------|-----------|--------|-------|
| APAS-D28-A | AL6063-T5 | 0.42 | D28-A |

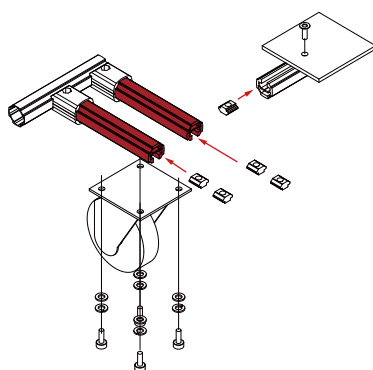
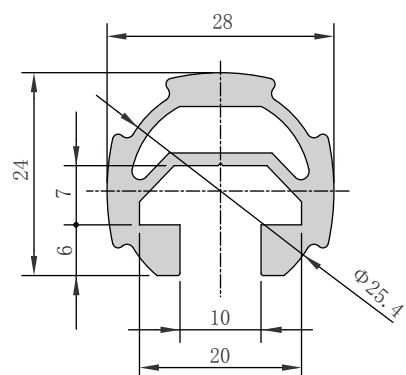

| 型号 | 材质 | 重量kg/m | 订货编号 |
|------------|-----------|--------|-------|
| APAS-D28-B | AL6063-T5 | 0.66 | D28-B |

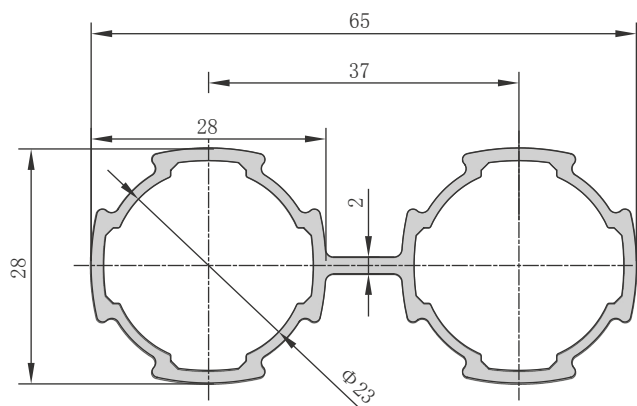

| 型号 | 材质 | 重量kg/m | 订货编号 |
|------------|-----------|--------|-------|
| APAS-D28-C | AL6063-T5 | 0.79 | D28-C |

purpose

D28-C线棒用途：

D28-C wire rod is a kind of lean tube, which is mainly used in the frame structure with high bearing capacity.

D28-C线棒属于重型精益管，主要应用于具有较高承载能力的框架结构。

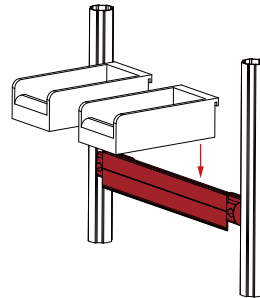
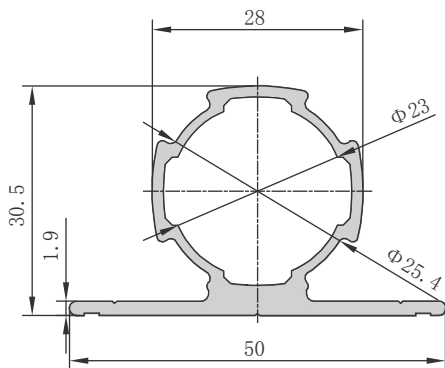
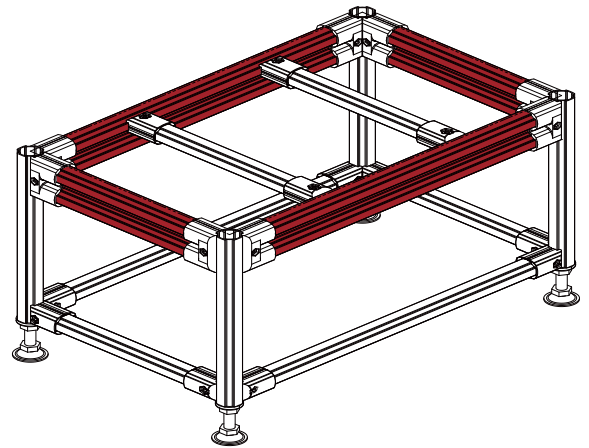

| 型号 | 材质 | 重量kg/m | 订货编号 |
|------------|-----------|--------|-------|
| APAS-D28-D | AL6063-T5 | 0.67 | D28-D |

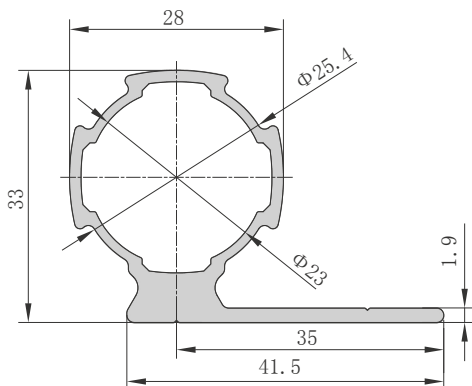

| 型号 | 材质 | 重量kg/m | 订货编号 |
|------------|-----------|--------|-------|
| APAS-D28-E | AL6063-T5 | 0.62 | D28-E |

滑条

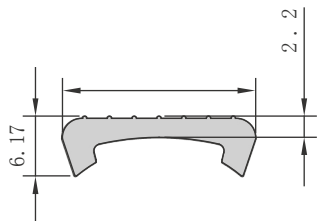

| 型号 | 材质 | 重量kg/m | 订货编号 |
|------------|------|--------|-------|
| APAS-D28-F | HDPE | 0.05 | D28-F |

90度外扣件

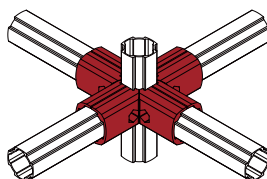
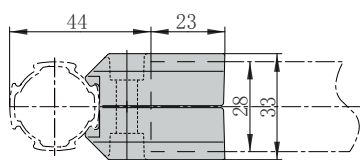
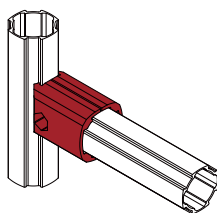
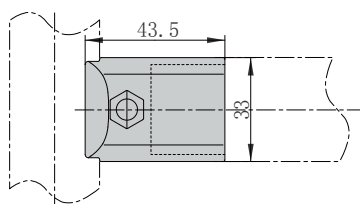

| 型号 | 材质 | 重量kg/套 | 订货编号 |
|--------|-------|--------|----------|
| 90度外扣件 | 铸铝/铸锌 | 0.056 | D28-JT-A |

90度内涨件

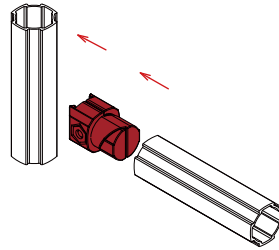
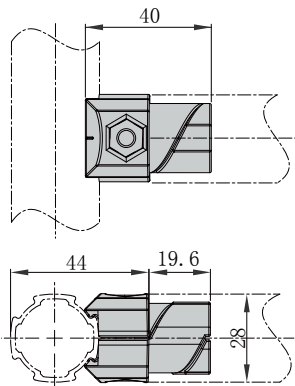

| 型号 | 材质 | 重量kg/套 | 订货编号 |
|--------|-------|--------|----------|
| 90度内涨件 | 铸铝/铸锌 | 0.05 | D28-JT-B |

L型外扣件

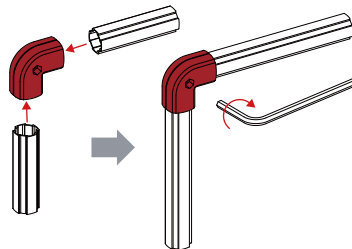
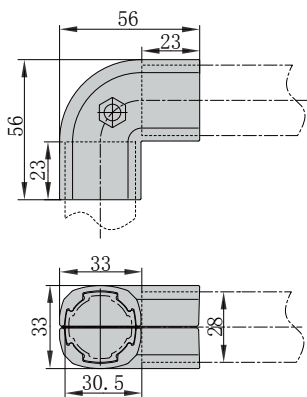

| 型号 | 材质 | 重量kg/套 | 订货编号 |
|-------|-------|--------|----------|
| L型外扣件 | 铸铝/铸锌 | 0.097 | D28-JT-C |

L型内涨件

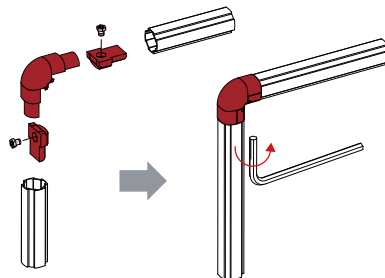
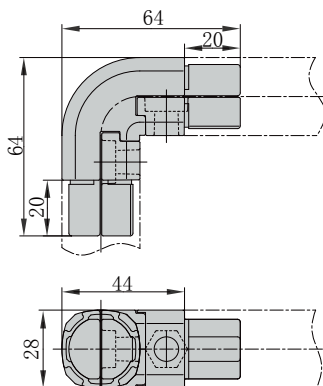

| 型号 | 材质 | 重量kg/套 | 订货编号 |
|-------|-------|--------|----------|
| L型内涨件 | 铸铝/铸锌 | 0.15 | D28-JT-D |

45度外扣件

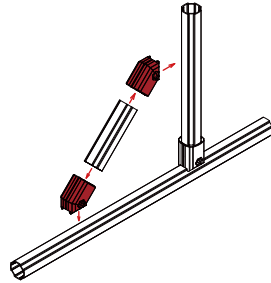
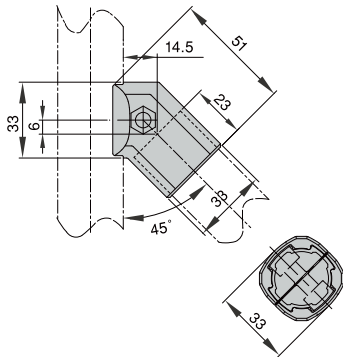

| 型号 | 材质 | 重量kg/套 | 订货编号 |
|--------|-------|--------|----------|
| 45度外扣件 | 铸铝/铸锌 | 0.061 | D28-JT-E |

45度内涨件

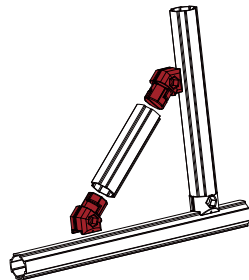
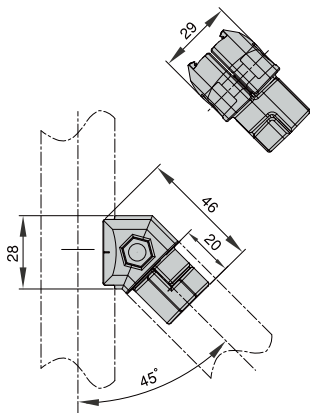

| 型号 | 材质 | 重量kg/套 | 订货编号 |
|--------|-------|--------|----------|
| 45度内涨件 | 铸铝/铸锌 | 0.055 | D28-JT-F |

万向外扣件

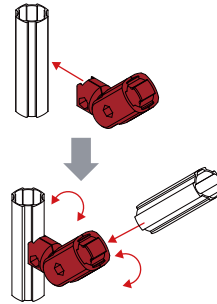
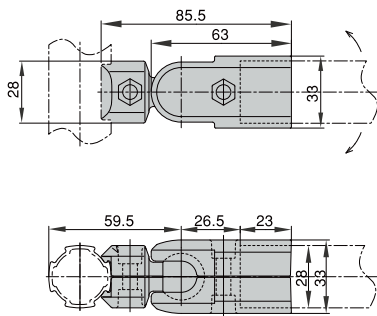

| 型号 | 材质 | 重量kg/套 | 订货编号 |
|-------|-------|--------|----------|
| 万向外扣件 | 铸铝/铸锌 | 0.13 | D28-JT-G |

万向内涨扣件

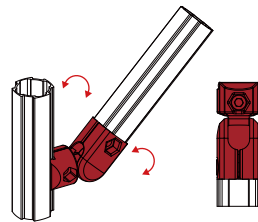
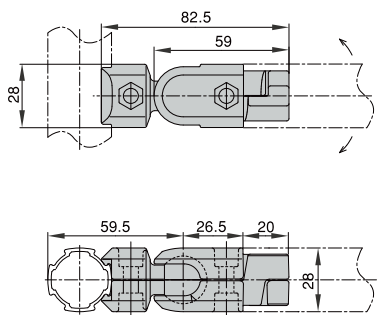

| 型号 | 材质 | 重量kg/套 | 订货编号 |
|--------|-------|--------|----------|
| 万向内涨扣件 | 铸铝/铸锌 | 0.11 | D28-JT-H |

十字扣件

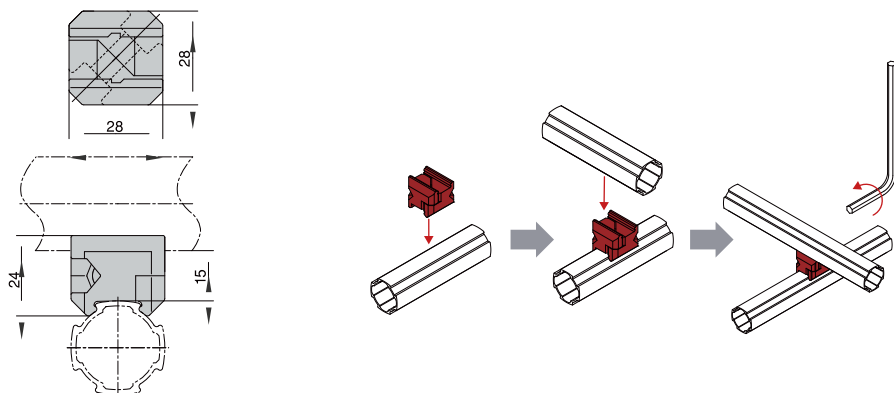

| 型号 | 材质 | 重量kg/套 | 订货编号 |
|------|-------|--------|----------|
| 十字扣件 | 铸铝/铸锌 | 0.05 | D28-JT-I |

平行扣件1

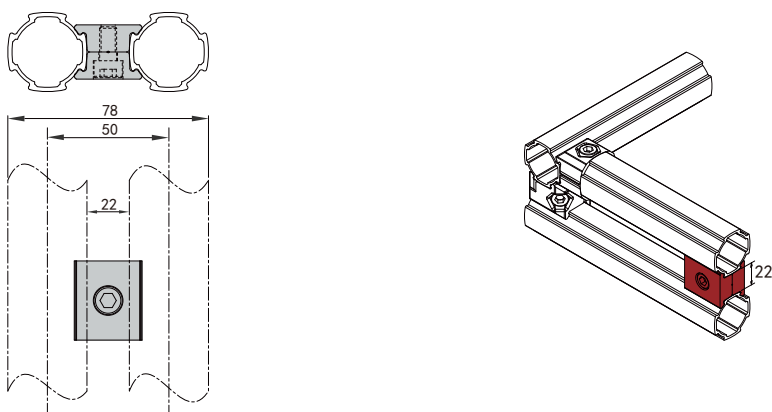

| 型号 | 材质 | 重量kg/套 | 订货编号 |
|-------|-------|--------|-----------|
| 平行扣件1 | 铸铝/铸锌 | 0.036 | D28-JT-J1 |

平行扣件2

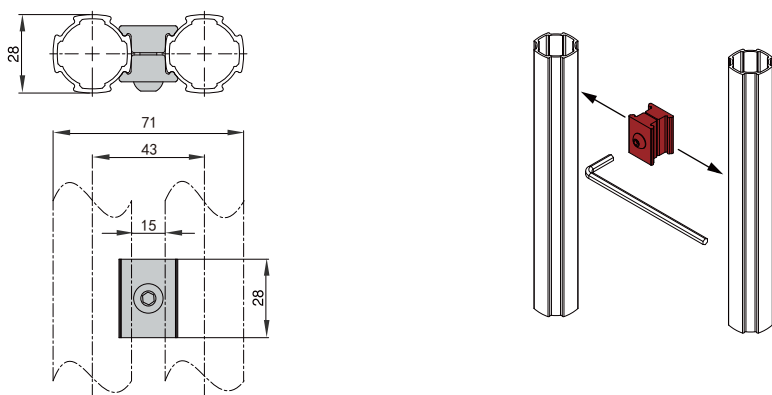

| 型号 | 材质 | 重量kg/套 | 订货编号 |
|-------|-------|--------|------------|
| 平行扣件2 | 铸铝/铸锌 | 0.05 | D28-JT-J2E |

板扣件

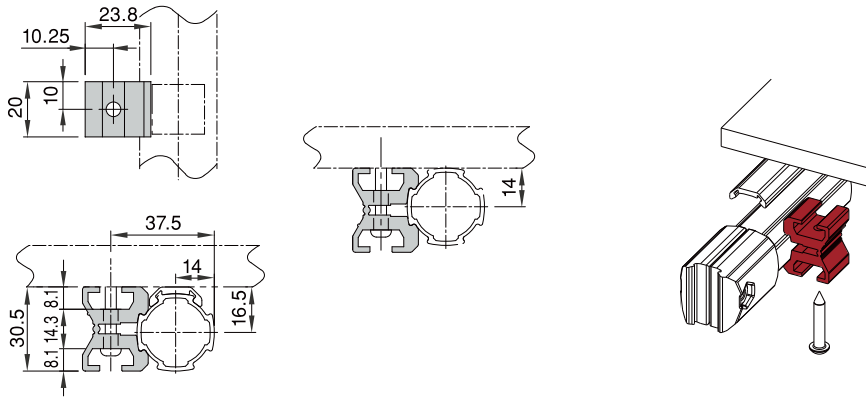

| 型号 | 材质 | 重量kg/套 | 订货编号 |
|-----|-------|--------|-----------|
| 板扣件 | 铸铝/铸锌 | 0.02 | D28-JT-KE |

45度斜撑扣件

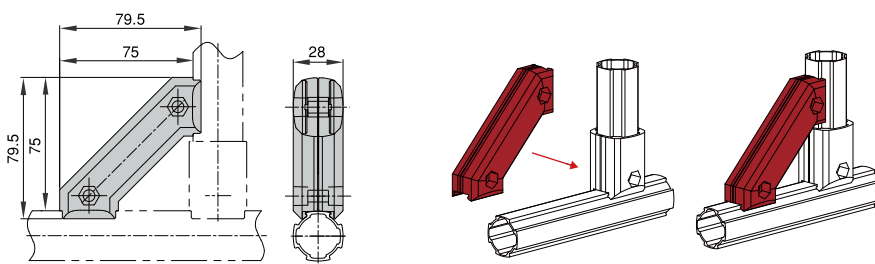

| 型号 | 材质 | 重量kg/套 | 订货编号 |
|---------|-------|--------|----------|
| 45度斜撑扣件 | 铸铝/铸锌 | 0.12 | D28-JT-L |

90度双排外扣件

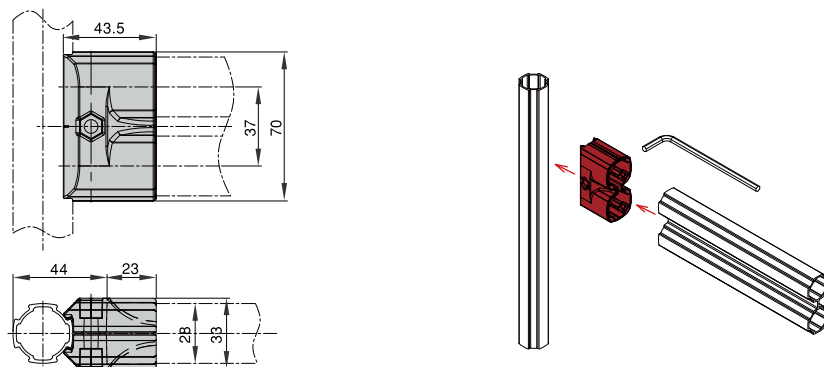

| 型号 | 材质 | 重量kg/套 | 订货编号 |
|----------|-------|--------|----------|
| 90度双排外扣件 | 铸铝/铸锌 | 0.13 | D28-JT-M |

双卡环扣件

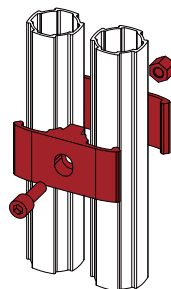
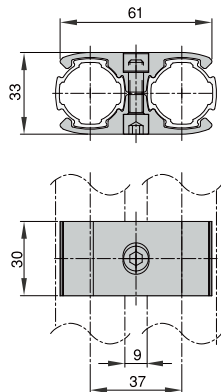

| 型号 | 材质 | 重量kg/套 | 订货编号 |
|-------|-------|--------|----------|
| 双卡环扣件 | 铸铝/铸锌 | 0.055 | D28-JT-N |

直线内涨扣件

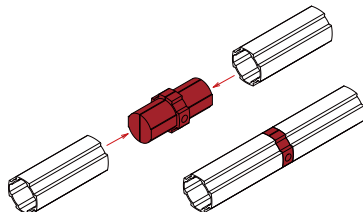
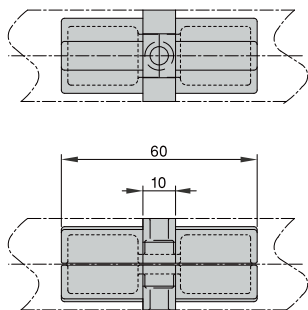

| 型号 | 材质 | 重量kg/套 | 订货编号 |
|--------|-------|--------|----------|
| 直线内涨扣件 | 铸铝/铸锌 | 0.011 | D28-JT-0 |

型材转接块

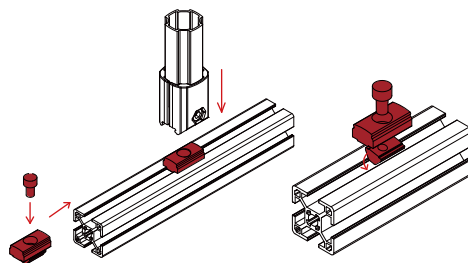
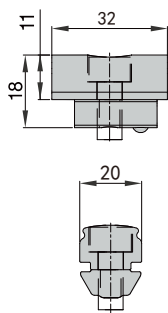

| 型号 | 材质 | 重量kg/套 | 订货编号 |
|-------|-------|--------|----------|
| 型材转接块 | 铸铝/铸锌 | 0.011 | D28-JT-P |

塑料封堵

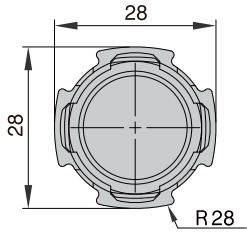

| 型号 | 材质 | 重量kg/m | 订货编号 |
|------|------|--------|----------|
| 塑料封堵 | LDPE | 0.018 | D28-JT-Q |

型材端面连接套

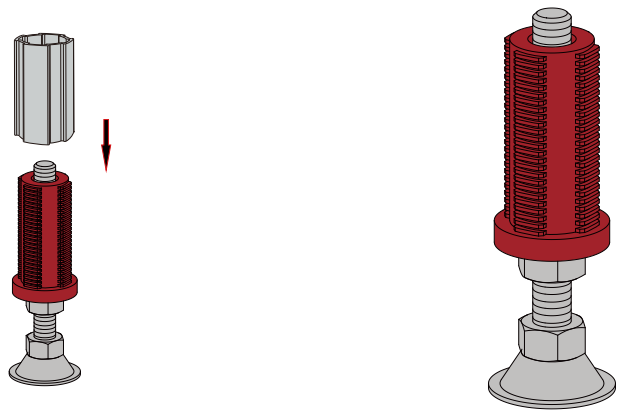
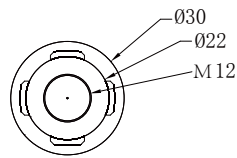
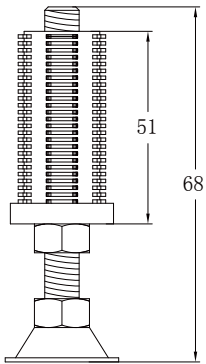

| 型号 | 材质 | 重量kg/m | 订货编号 |
|---------|----|--------|----------|
| 型材端面连接套 | 塑料 | 0.015 | D28-JT-R |

膨胀万向脚轮

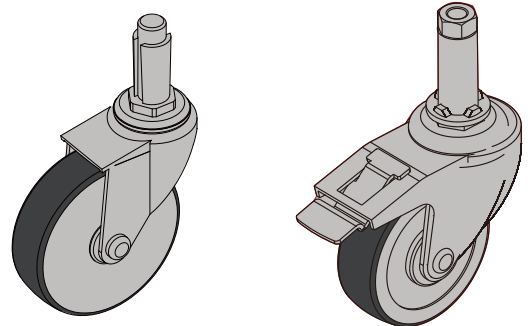
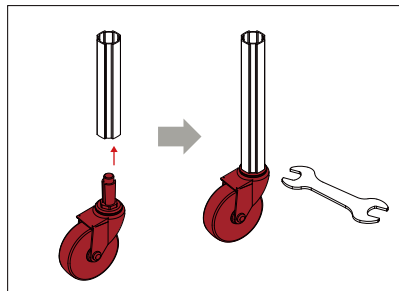
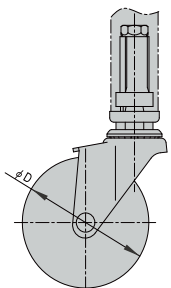

| 材质 | 聚氨酯/防静电 | 聚氨酯/防静电 | 聚氨酯/防静电 |
|------|------------|-------------|-------------|
| 规格 | D75 (3寸) | D100 (4寸) | D125 (5寸) |
| 负载 | 90kg | 100kg | 125kg |
| 订货编号 | D28-W75D | D28-W100D | D28-W125D |
| 订货编号 | D28-W75D-C | D28-W100D-C | D28-W125D-C |

滑动套

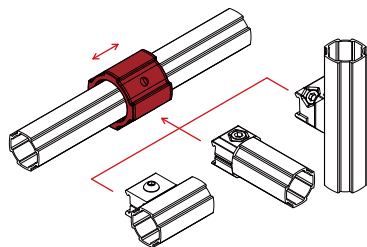
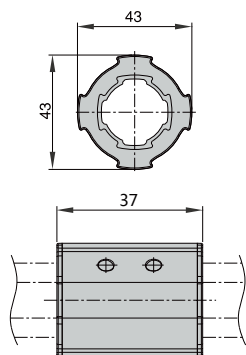

| 型号 | 材质 | 重量kg/m | 订货编号 |
|-----|---------------|--------|----------|
| 滑动套 | 铝合金/ADC-12(白) | 0.045 | D28-JT-S |

旋转套

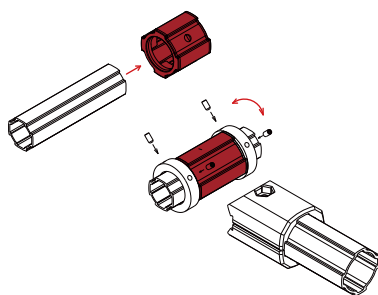
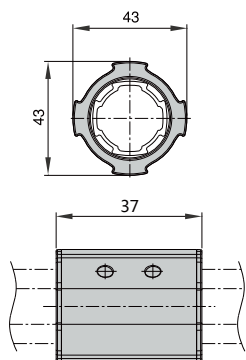

| 型号 | 材质 | 重量kg/m | 订货编号 |
|-----|---------------|--------|-----------|
| 旋转套 | 铝合金/ADC-12(白) | 0.045 | D28-JT-T1 |

旋转套固定环

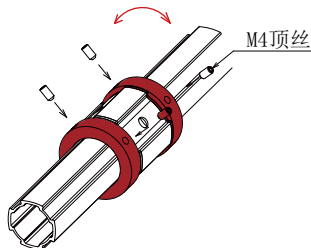
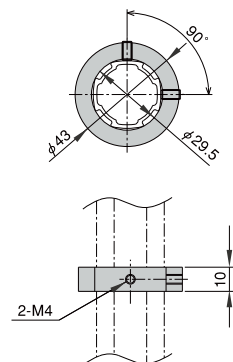

| 型号 | 材质 | 重量kg/m | 订货编号 |
|--------|---------------|--------|-----------|
| 旋转套固定环 | 铝合金/ADC-12(白) | 0.021 | D28-JT-T2 |

线棒流利条

安装方便快捷，物品放置于上方运行流畅。

| | |
|------|-------------------------------------|
| 框架材质 | 铝合金框架 |
| 滚轮材质 | PE |
| 滚轮颜色 | 白色/黄色/黑色 |
| 每米承重 | 80kg |
| 配件 | 配专用导轨接头 |
| 订货编号 | APAS-LL40-XXmm(长度) - W(白)/Y(黄)/B(黑) |

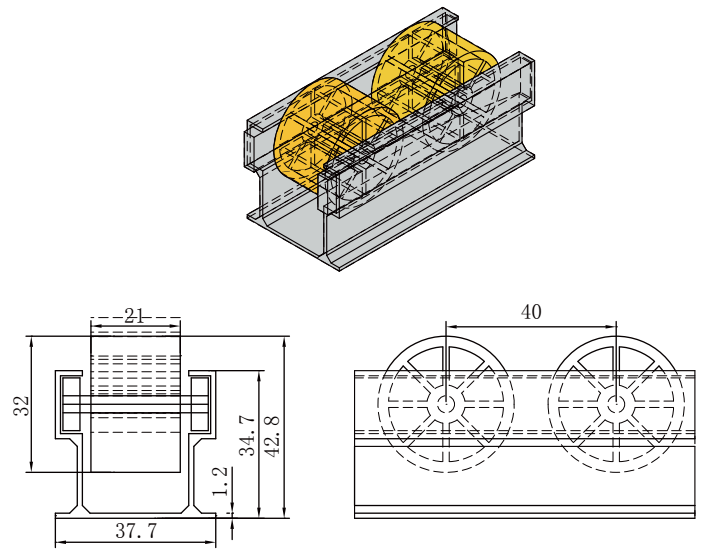

线棒流利条

铝合金骨架外表美观，钢板骨架承重能力强。

| | |
|------|--------------------------------|
| 框架材质 | 镀锌钢板 |
| 滚轮材质 | PE |
| 滚轮颜色 | 白色/黑色 |
| 每米承重 | 200kg |
| 配件 | 配专用导轨接头 |
| 订货编号 | APAS-LL60-XXmm(长度) - W(白)/B(黑) |

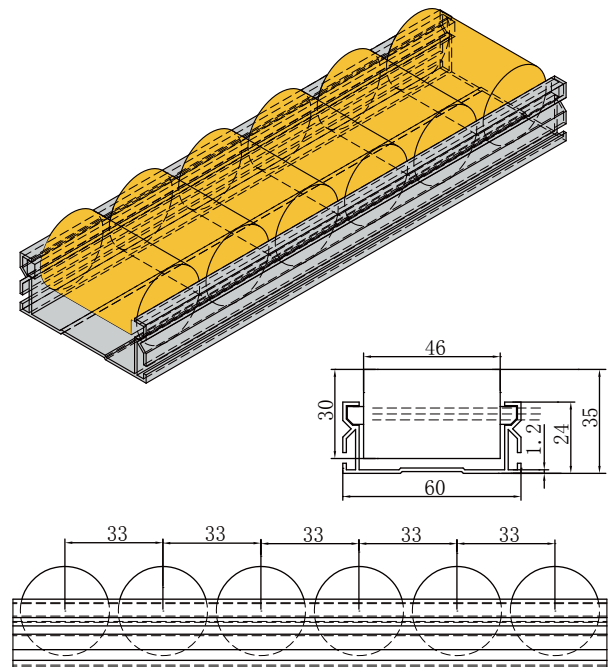

LP40-C

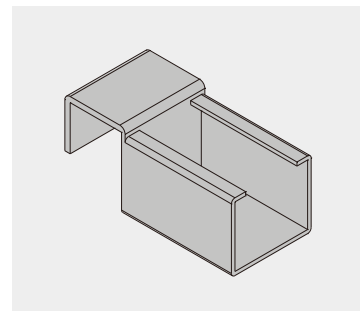
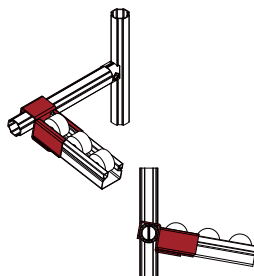
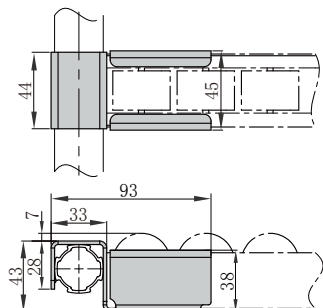

| 型号 | 材质 | 重量kg/套 | 订货编号 |
|--------|------|--------|------------|
| LP40-C | 钢板镀锌 | 0.2 | D28-LP40-C |

LP40-D

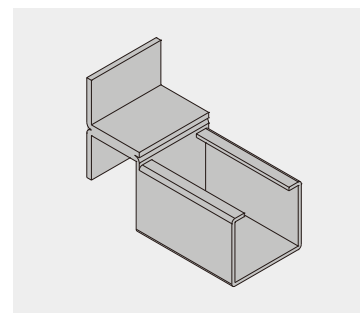
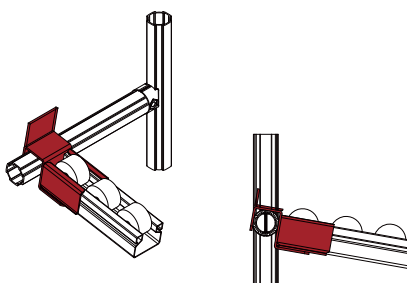
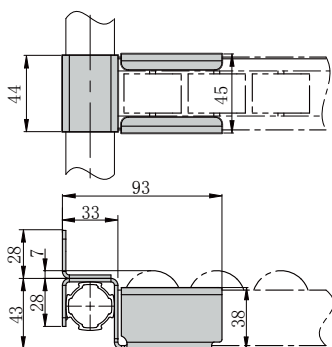

| 型号 | 材质 | 重量kg/套 | 订货编号 |
|--------|------|--------|------------|
| LP40-D | 钢板镀锌 | 0.23 | D28-LP40-D |

LP40-DW

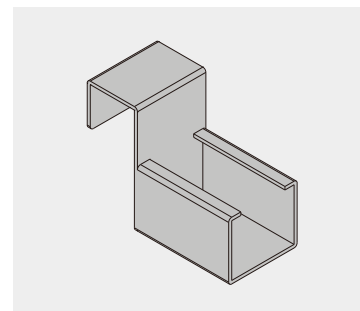
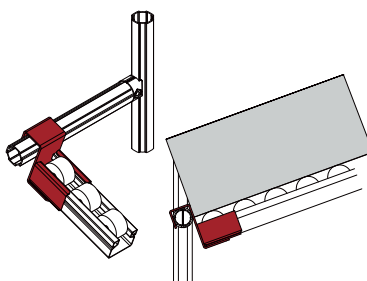
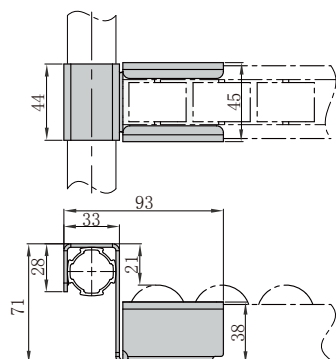

| 型号 | 材质 | 重量kg/套 | 订货编号 |
|---------|------|--------|-------------|
| LP40-DW | 钢板镀锌 | 0.23 | D28-LP40-DW |

LP40-E

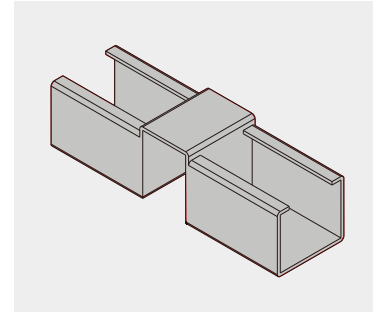
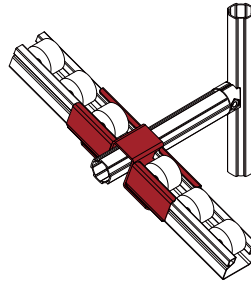
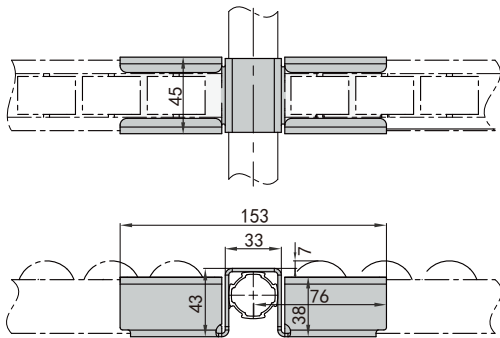

| 型号 | 材质 | 重量kg/套 | 订货编号 |
|--------|------|--------|------------|
| LP40-E | 钢板镀锌 | 0.31 | D28-LP40-E |

LP40-P

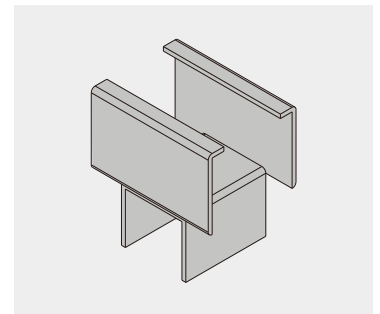
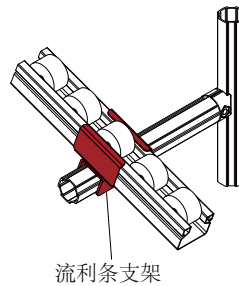
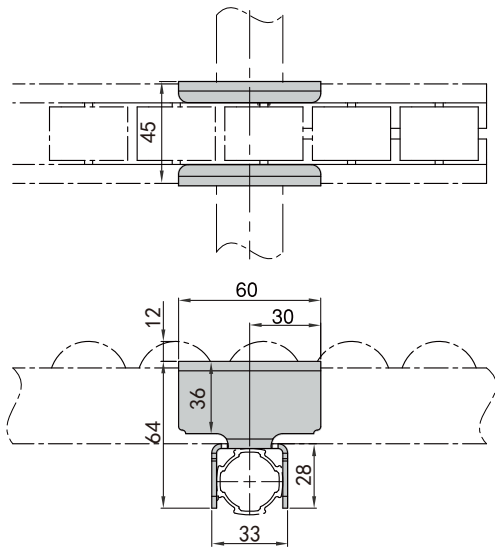

| 型号 | 材质 | 重量kg/套 | 订货编号 |
|--------|------|--------|------------|
| LP40-P | 钢板镀锌 | 0.2 | D28-LP40-P |

Edition/版4.0



Contact US

联系艾普斯：

Tel : 022-87887696

Fax : 022-87920088

E-mail: apastj@163.com

ADDRESS: 天津市西青经济技术开发区赛达国际工业城A3-2